

SLABFORM

SINCE'96

2025

FACTORY CENTER

Address : Makine İhtisas OSB. 5.Cad. No:17
Dilovası / Kocaeli / TÜRKİYE

Phone : +90 262 742 06 37
Web : ozleriskele.com
E-mail : info@ozleriskele.com - ozler@ozleriskele.com

İZMİR BRANCH

Address : Kavaklıdere Mah. Ankara Cd. No:405/1
Bornova / İZMİR

Phone : +90 232 479 01 37
Branch Manager : Fatih Mehmet AYPACI
E-mail : fatih@ozleriskele.com

ANKARA BRANCH

Address : Tepe Prime C Blok Kat 8 No:206/C-101
Çankaya / ANKARA

Phone : +90 532 173 98 74
Branch Manager : İsmail GÜNOĞLU
E-mail : ismail.gunoglu@ozleriskele.com

ROMANIA BRANCH

Address : Strada DN CB Nr:274 Sat GLINA, Comuna
GLINA / ILFOV ROMANIA

Phone : +40 371 340 262
Branch Manager : İbrahim KARSLI
Web : ozler.ro
E-mail : office@ozler.ro

SLABFORM / KALIP ALTI İSKELE SİSTEMİ

SLABFORM, döşeme ve kiriş altında taşıyıcı iskele olarak kullanılır. Masa kalıbı, ağır yük iskelesi ve merdiven kulesi gibi üç farklı şekilde kullanılabilir. Zemini teraziye almak için TS EN 74-3 sertifikalı alt ayar milleri, döşeme ve kiriş altını teraziye almak için ise 4 yollu veya U başlıklı üst ayar milleri kullanılır. SLABFORM, demonte edilmeden taşıma arabaları ve vinç ile deplase edilebildiği için işçilik maliyetlerinden ve zamandan tasarruf sağlar. Çerçevesel standart olarak 150 cm genişliğinde ve 120 - 150 - 180 - 200 cm yüksekliğinde üretilir. TS EN 12813 sertifikalı SLABFORM çerçeveler 60*3,0 veya 60*4,0 mm, yatay ve diyagonal bağlantılar ise 34*2,5 mm TSE belgeli mekanik testlere tabi tutulmuş sanayi borularından üretilir. Üretimlerimizde robotik kesme, delme ve kaynak prosesleri uygulanmaktadır. Çerçevesel fırın boya işlemine tabi tutulmadan önce kumlama yapılarak yüzeyindeki kimyasal yağlardan arındırılır. Ayrıca talep halinde ürünlerimiz TS 914 EN ISO 1461 standartlarına göre daldırma galvaniz kaplanabilir.

SLABFORM / SHORING SCAFFOLDING SYSTEM

SLABFORM is used as load carrier scaffolding under slab and beam. It can be used in 3 different ways such as table form, heavy load scaffold and stair tower. TS EN 74-3 certified base and head jacks are used to balance the floor and the bottom of the formwork. The SLABFORM can be displaced by transport trolleys and crane without disassembling, thus saving labor costs and time. The frames are manufactured as 150 cm width and 120 - 150 - 180 - 200 cm high as standard. TS EN 12813 certified SLABFORM frames are produced from 60 * 3.0 or 60 * 4.0 mm, horizontal and diagonal braces are produced from 34 * 2.5 mm TSE certified mechanical tubes. Robotic cutting, drilling and welding processes are applied in our production. The steel products are cleaned with sandblasting before oven painting because of the industrial chemical oil. Upon request, our products can be hot dip galvanized according to TS 914 EN ISO 1461 standards.



TS EN 12813 SLABFORM - CLASS - A - B1 - B2

SLABFORM

KALIP ALTI İSKELE SİSTEMİ SHORING SCAFFOLDING SYSTEM





SLABFORM Masa Kalıp Uygulaması Montaj Detayları Floor Tables Assembly Details

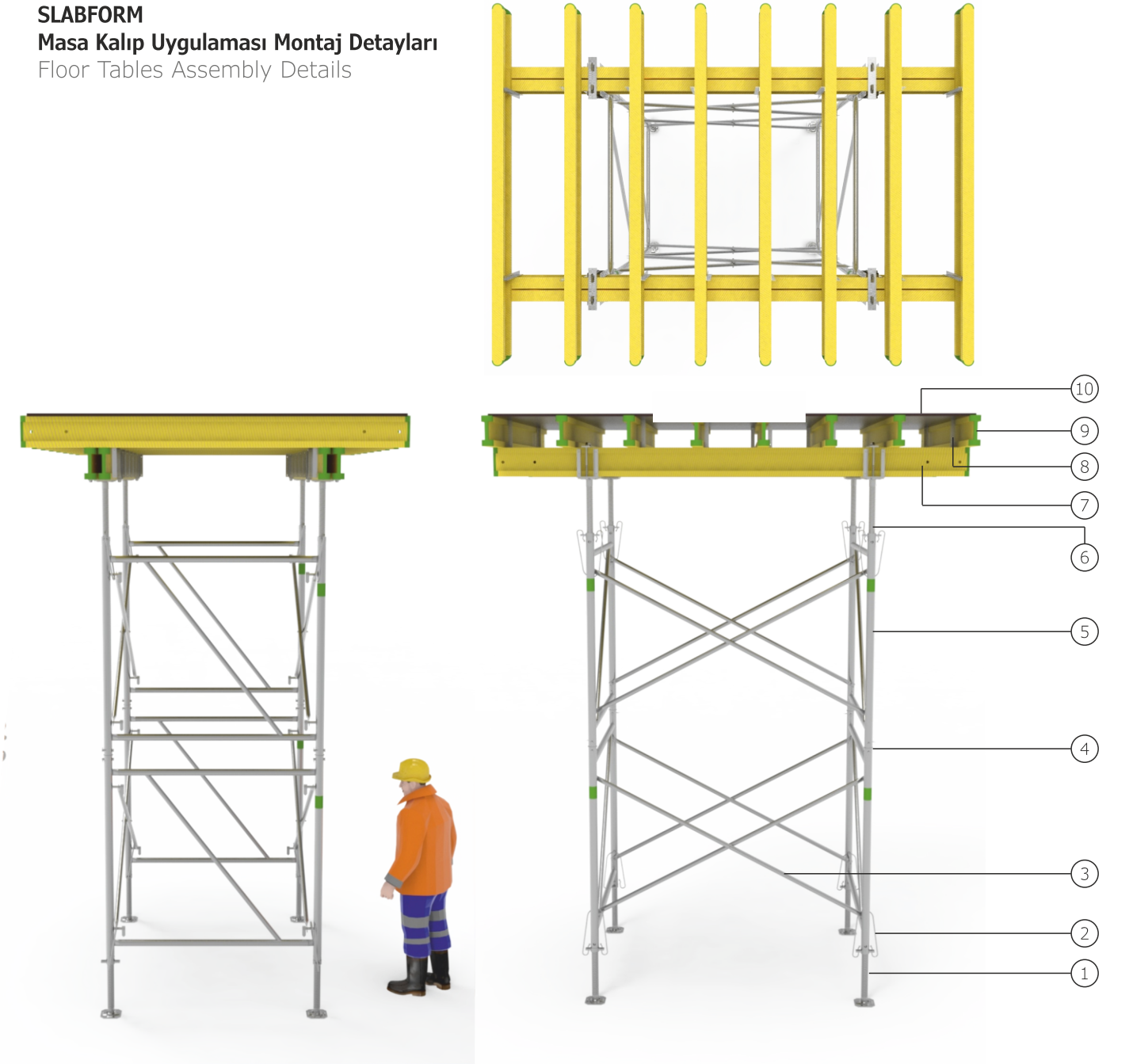

- 1 - Alt Ayar Mili Ø48 / Base Jack Ø48
- 2 - Ayar Mili Kancası / Spindle Hook
- 3 - Slabform Çapraz / Slabform Diagonal
- 4 - İskele Ekleme Elemanı Ø60 / Scaffold Connection Ø60
- 5 - Slabform Çerçeve / Slabform Frame
- 6 - Ayar Mili DYB Ø48 / H20 Head Jack Ø48
- 7 - Ana Taşıyıcı - H20 Ahşap Kiriş / Main Beam - H20 Wooden Beam
- 8 - Kiriş Bağlama Köşebentli / Girder Connector
- 9 - Tali Taşıyıcı - Izgara / Secondary Beam - H20 Wooden Beam
- 10 - Plywood



Maksimum Taşıma Kapasitesi 750 kg
Maximum Carrying Capacity 750 kg



Maksimum Taşıma Kapasitesi 500 kg
Maximum Carrying Capacity 500 kg



Masa Kalıbı İskelesi İçin Taşıma Aşamaları;
Floor Tables Carrying Steps;

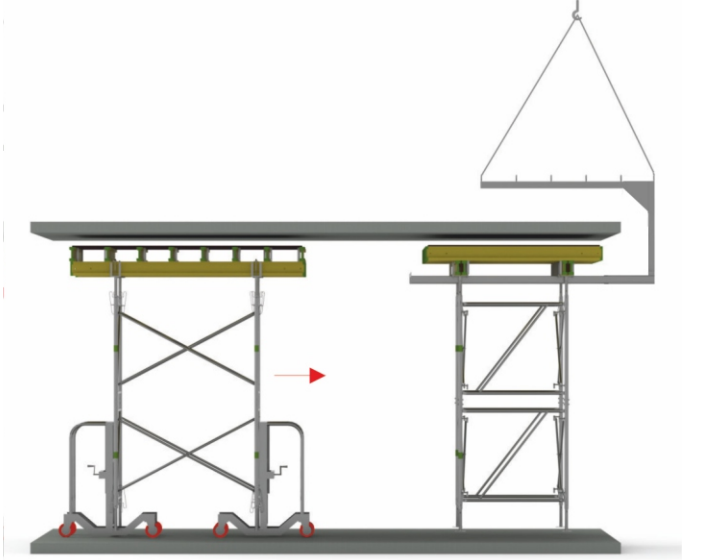
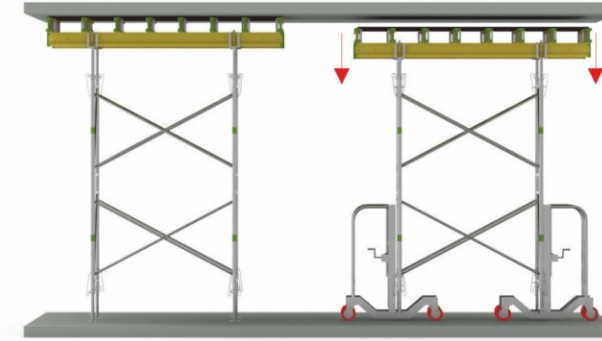

Step1

Üst katlara taşınacak olan masa kalıplar, taşıma arabası yardımıyla sırasıyla döşeme kenarına getirilir.
Floor tables that are going to be moved to the upper levels are separated and brought near to the slab's edge using the table carriers.

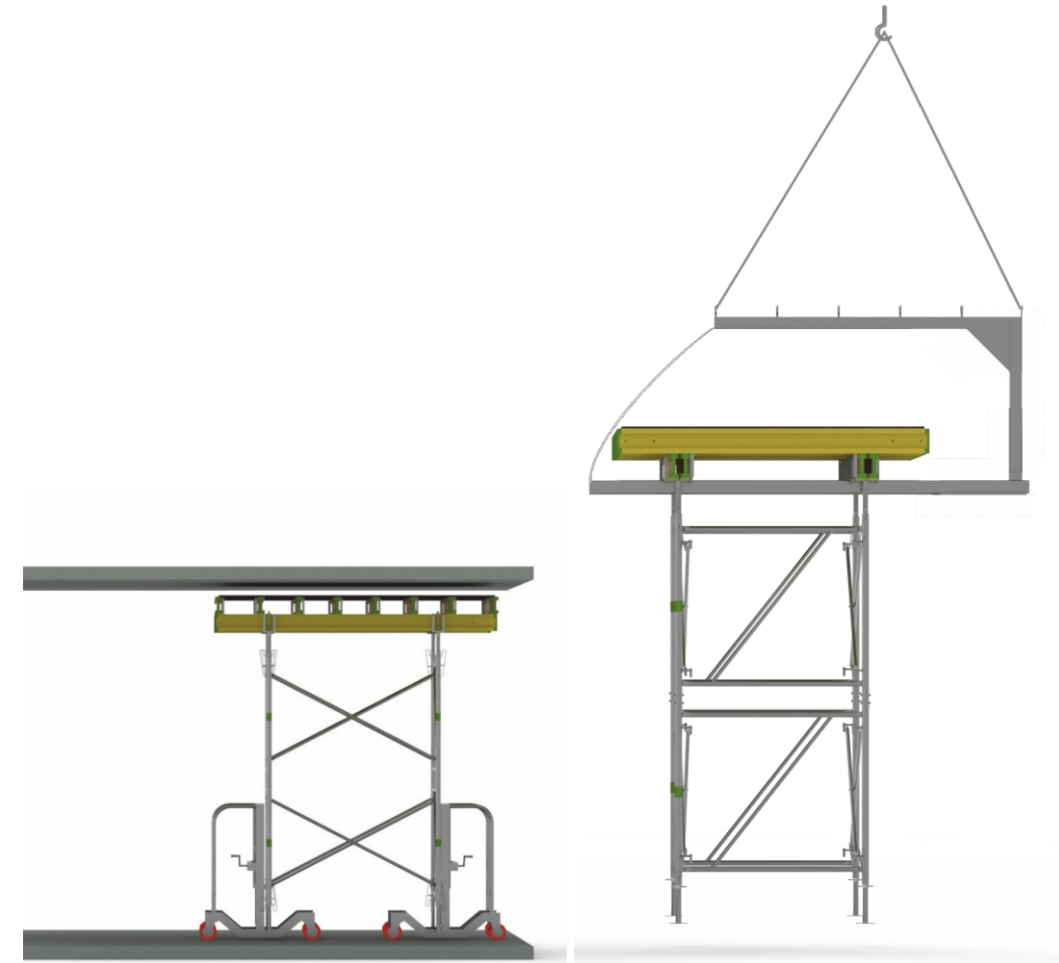

Step2

Döşeme kenarına getirilen masa kalıbı, masa taşıma çatalı yardımıyla istenilen bölgeye taşınır.
Floor tables that are near the edge are moved to the desired floor using table lifting component.



Sabiha Gökçen
Airport
Project
İstanbul



Yerinde döküm köprü kalıbı kurulum aşamaları / Bridge formwork assembly steps

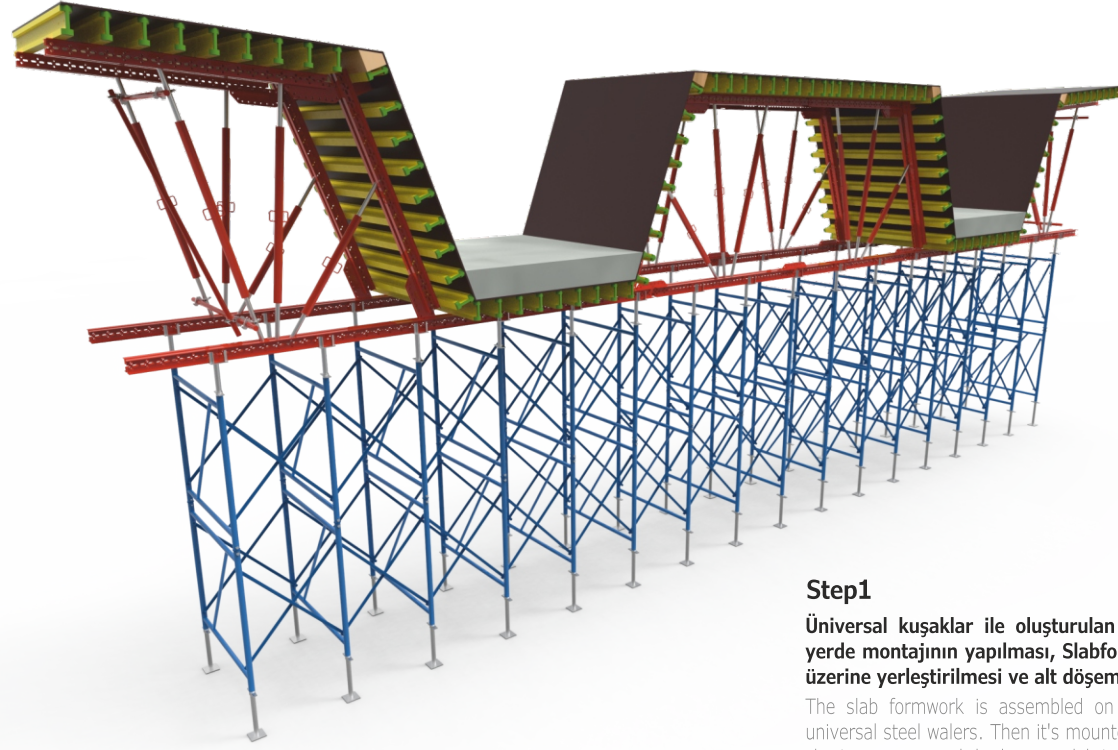

Step1

Üniversal kuşaklar ile oluşturulan kalıp sisteminin yerde montajının yapılması, Slabform iskele sistemi üzerine yerleştirilmesi ve alt döşeme beton dökümü.

The slab formwork is assembled on the ground using universal steel walers. Then it's mounted on the Slabform shoring system and the bottom slab is casted

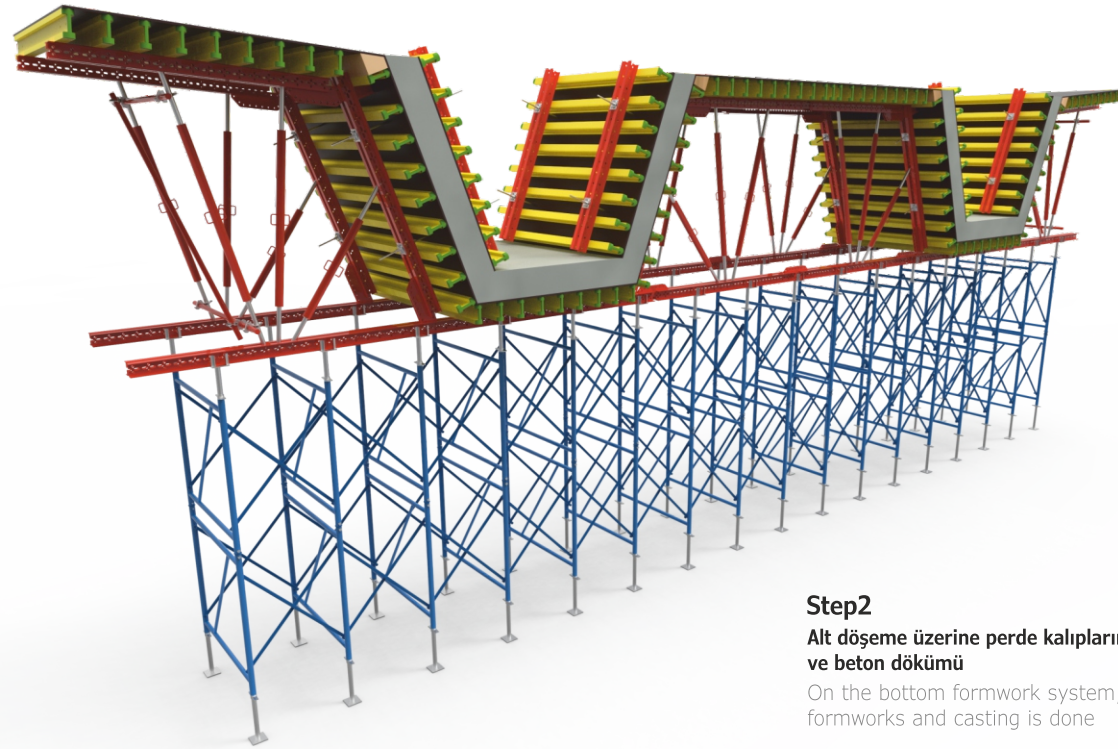

Step2

Alt döşeme üzerine perde kalıplarının yerleştirilmesi ve beton dökümü

On the bottom formwork system, it is placed Wall formworks and casting is done

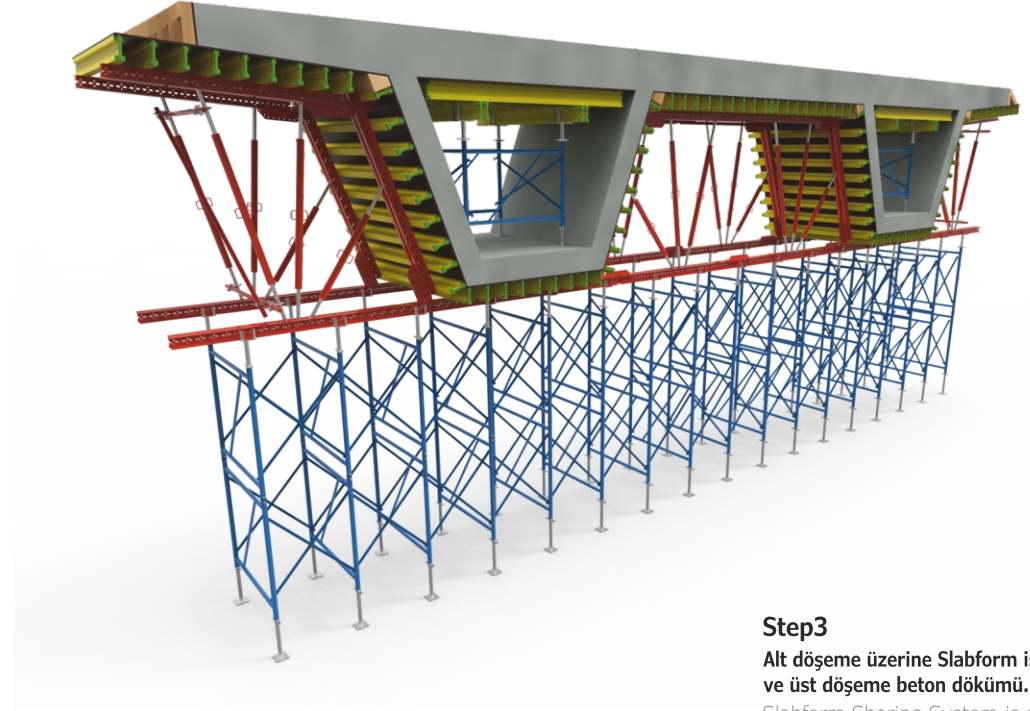

Step3

Alt döşeme üzerine Slabform iskele sistemi kurulumu ve üst döşeme beton dökümü.

Slabform Shoring System is placed on the bottom slab. Then, the top slab is casted.

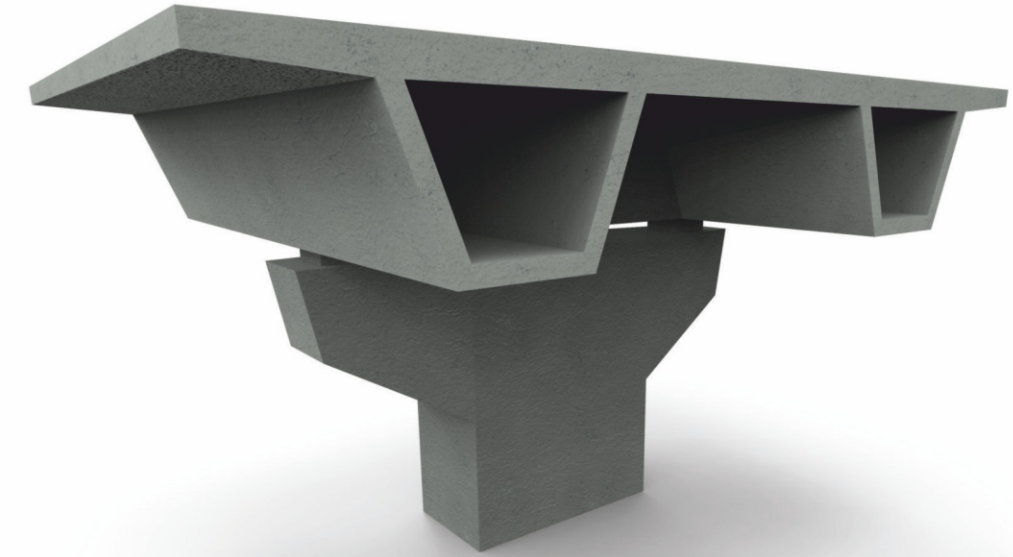

Step4

İskele ve kalıp sisteminin sökümü sonrası köprü döşemesinin görünüşü.

Formwork and shoring system is removed. The shape of the casted bridge is as shown above.



Yavuz Sultan
Selim
Bridge
İstanbul



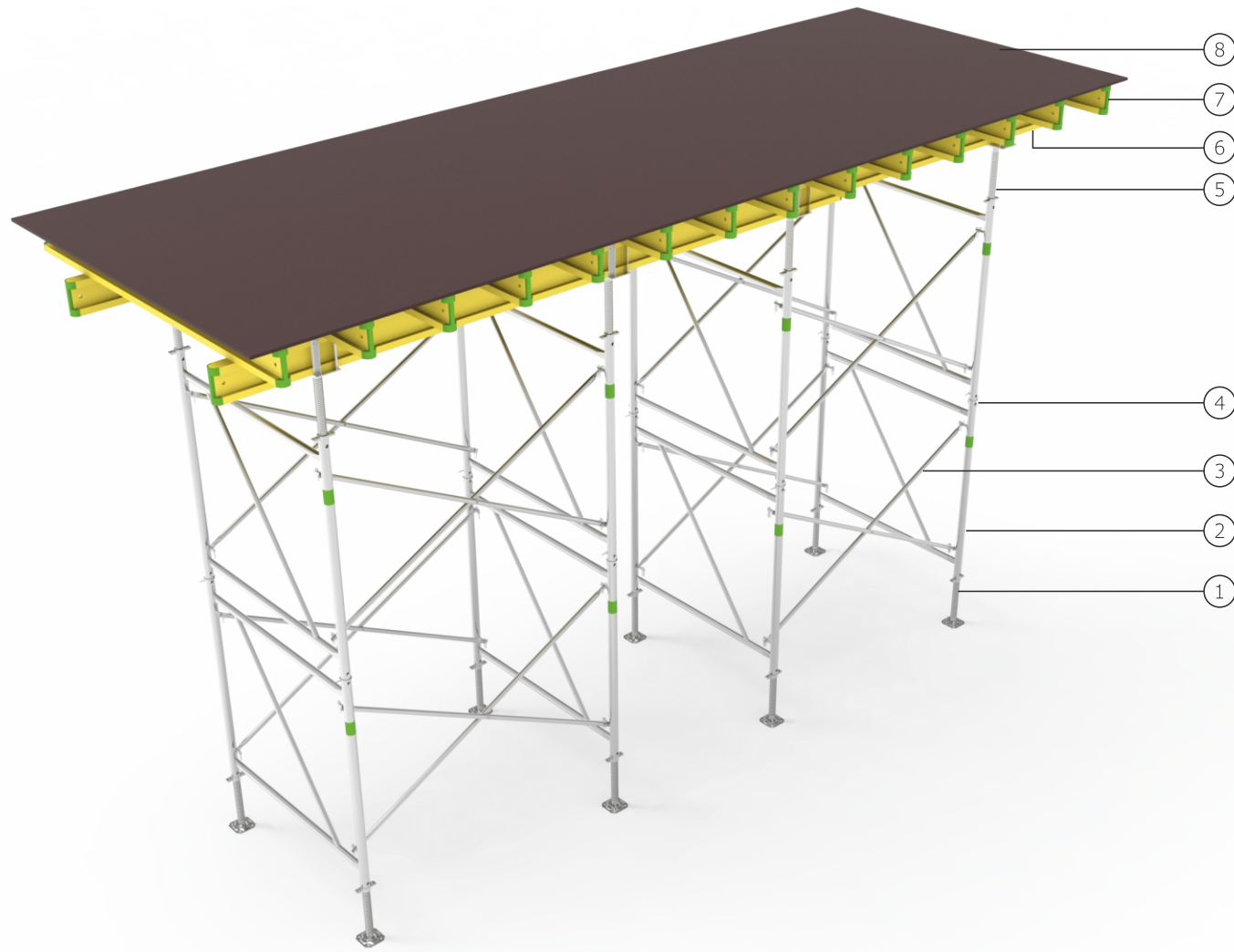

- 1 - Alt Ayar Mili Ø48 / Base Jack Ø48
- 2 - Slabform Çerçeve / Slabform Frame
- 3 - Slabform Çapraz / Slabform Diagonal
- 4 - İskele Ekleme Elemanı Ø60 / Scaffold Connection Ø60
- 5 - Ayar Mili DYB / H20 Head Jack
- 6 - Ana Taşıyıcı - H20 Ahşap Kiriş / Main Beam - H20 Wooden Beam
- 7 - Tali Taşıyıcı - Izgara / Secondary Beam - H20 Wooden Beam
- 8 - Plywood

SLABFORM KALIP ALTI İSKELE KURULUM AŞAMALARI

1. İskele kurulum projesi dikkate alınarak, alt ayar millerinin yükseklikleri ve konumları ayarlanır.
2. İlk sıra çerçeveler alt ayar millerinin üzerine monte edilir.
3. İlk sıra çerçevelere çapraz bağlantı elemanları monte edilir ve ilk sıra kurulumu tamamlanır.
4. İskele ekleme elemanları monte edilir.
5. İkinci sıra çerçeveler monte edilir.
6. Pim ve kopilya iskele ekleme elemanına monte edilerek ilk ve ikinci sıra çerçevelerin bağlantısı sağlanır.
7. İkinci sıra çerçevelere çapraz bağlantı elemanları monte edilir ve ikinci sıra kurulumu tamamlanır.
8. Projeye uygun yüksekliğe ulaşıncaya kadar uygulama tekrarlanır.
9. İskele kurulum projesi dikkate alınarak, Ayar mili DYB'lerin yükseklikleri ayarlanır.
10. İskele kurulum projesi dikkate alınarak ana taşıyıcı mahyalar ebatlarına ve bindirme paylarına göre montajlanır.
11. İskele kurulum projesi dikkate alınarak, tali taşıyıcılar montajlanır.
12. Plywood montajı ile kurulum tamamlanır.

SLABFORM SHORING SYSTEM ASSEMBLY STEPS

1. The location and height of the base jacks are adjusted according to the shoring system plan.
2. The first level's frames are mounted on the base jacks.
3. The first level's diagonal braces are connected to the frames. The first level's assembly is completed.
4. Scaffolding connection components are mounted on the frame.
5. The second level's frames are mounted.
6. Frame are combined by attaching the pin and pin split to the scaffolding connection component.
7. The second level's diagonal braces are connected to the frames. The second level's assembly is completed.
8. The steps are repeated until reaching the desired height.
9. The height of the H-20 head jacks are adjusted according to the shoring system plan.
10. Load carrying main beams are placed according to their lengths and their lap lengths as shown in the shoring system plan.
11. Secondary beams are placed according to the shoring system plan.
12. The system is ready after placing the plywood.



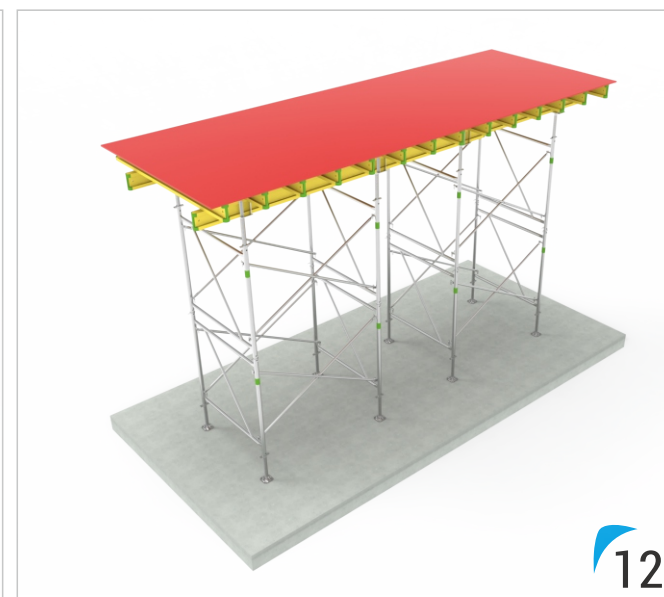
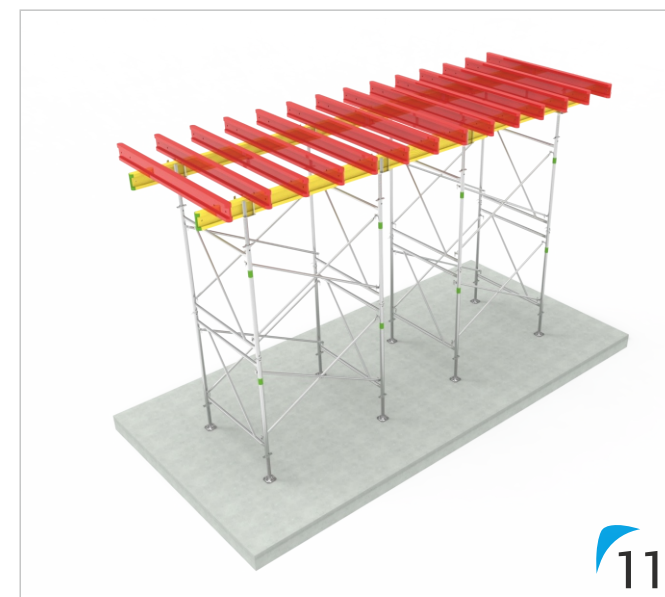
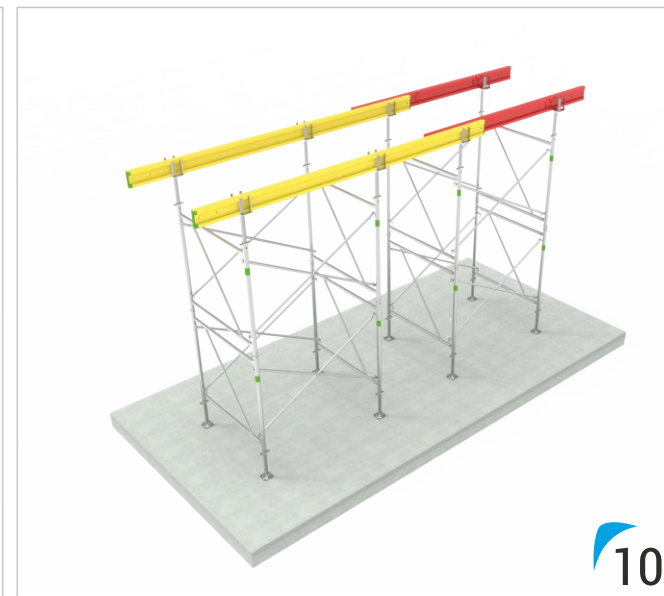
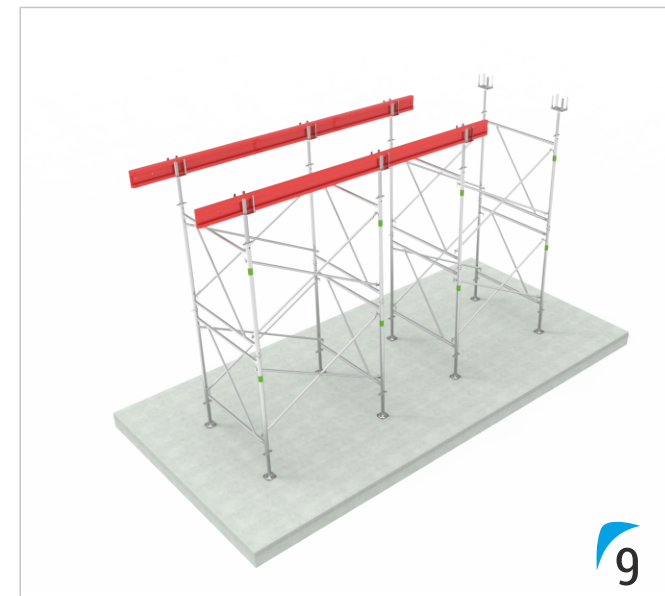
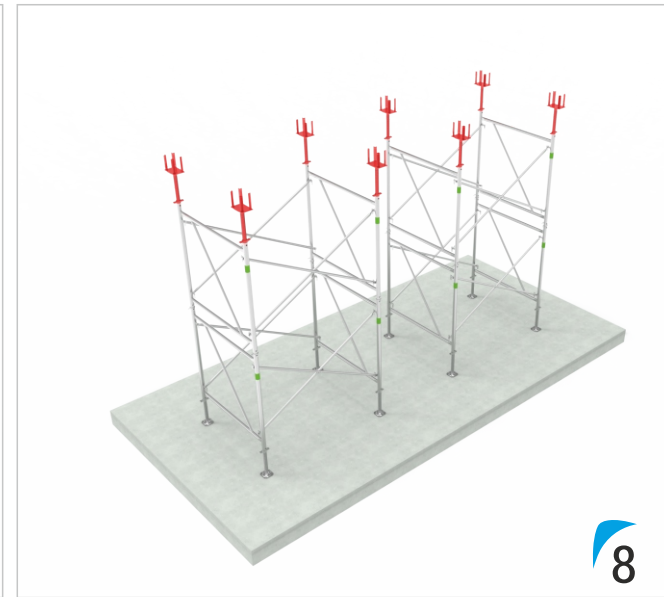
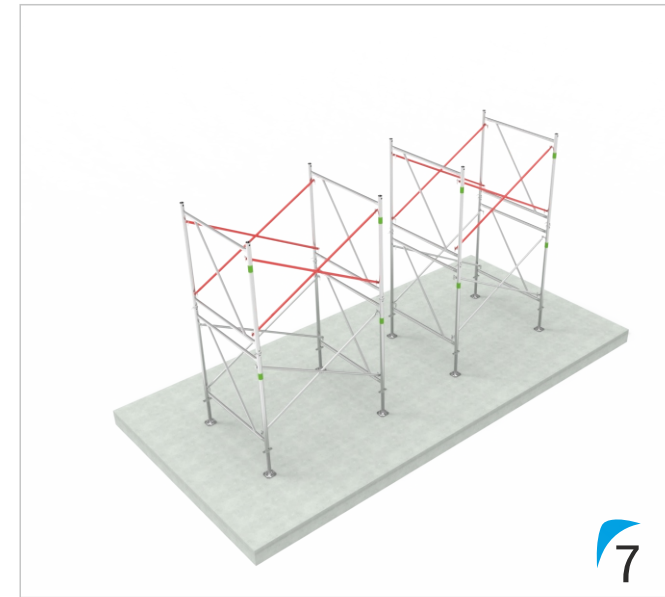
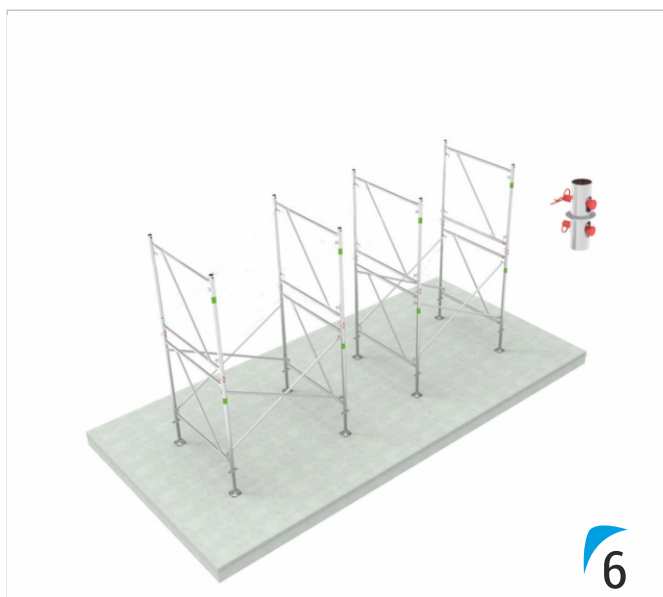
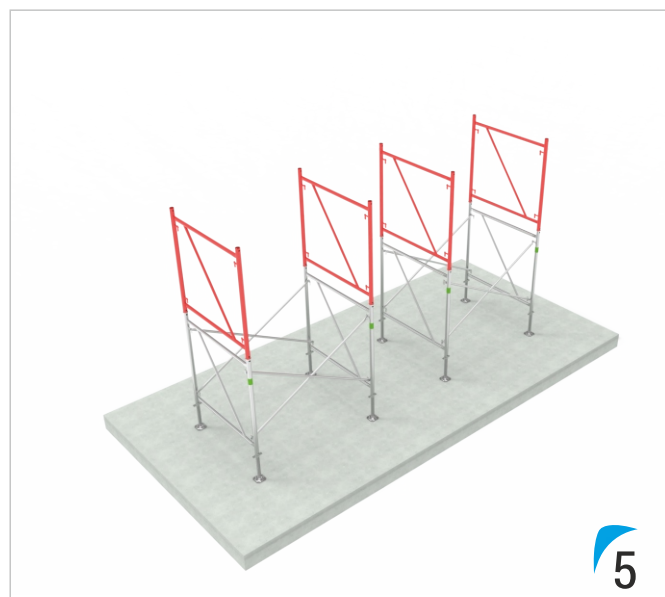
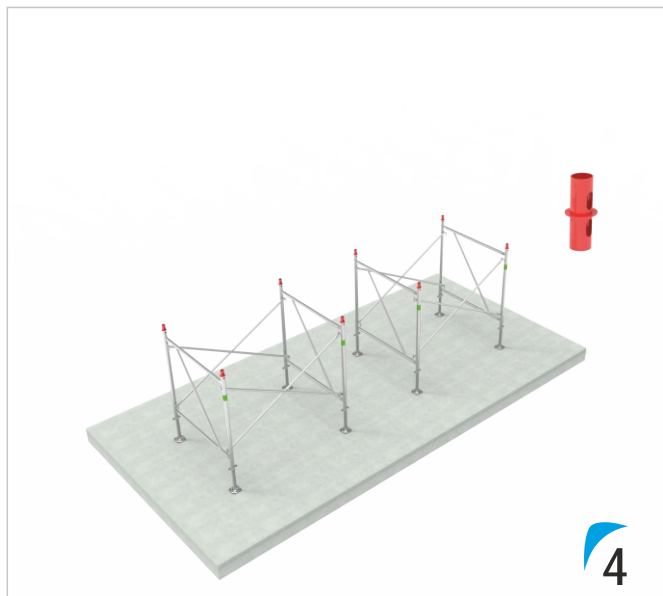
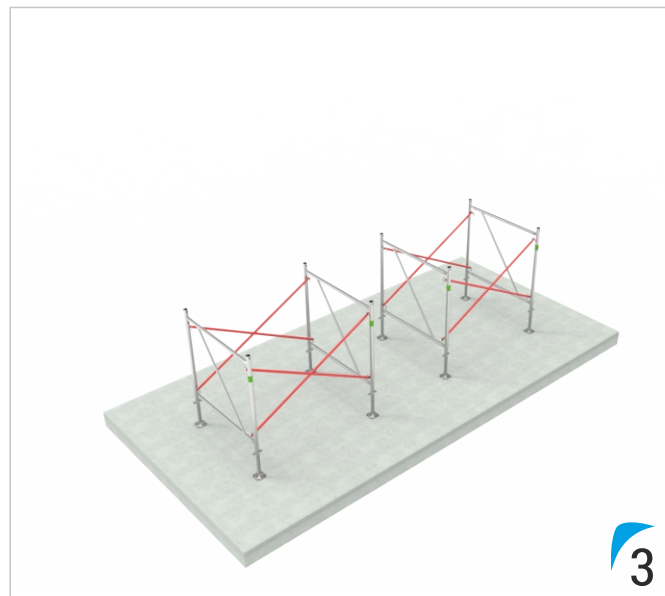
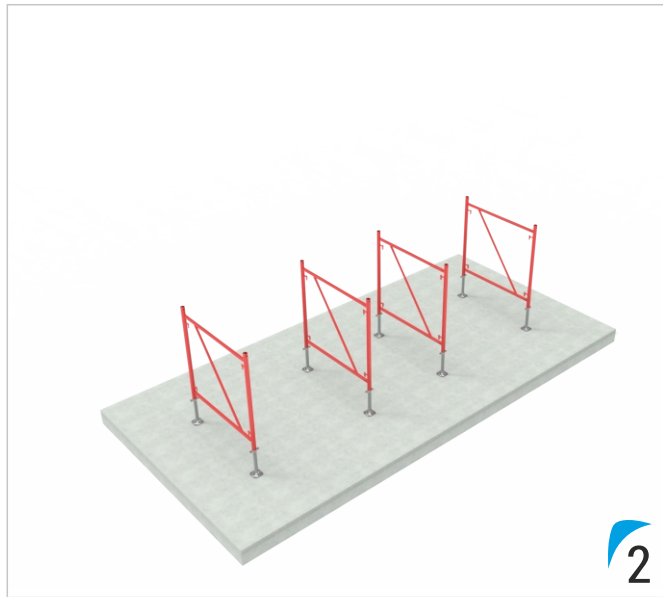
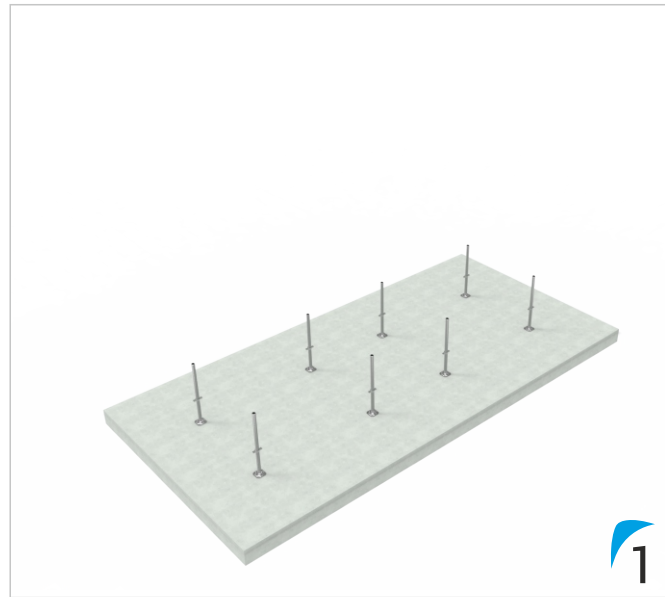

Kontrol Talimatları

- 1 - Kurulum sonrasında.
- 2 - Düzenli aralıklarla.
- 3 - Üzerinde bir değişiklik yapıldığında.
- 4 - Sismik sarsıntı veya kuvvetli rüzgarlar gibi olumsuz hava şartlarından sonra.
- 5 - Denge sağlanmasını etkileyebilecek diğer koşullara maruz kaldığında kontrol gerçekleştirilmelidir.

Checking Instructions

- 1 - After installation
- 2 - At regular time periods
- 3 - When a modification happens on it
- 4 - After negative weather conditions such as seismic tremor, strong winds
- 5 - Controls should be made when exposed to other conditions that could affect stability.

Paketleme / Packing

Ürünlerin nakliye ve stoklamaya uygun tavsiye edilen paketleme örnekleri.

Recommended packing methods of products for transportation and storage.

Slabform Çapraz Paketleme Örneği
Slabform Diagonal Packing Method

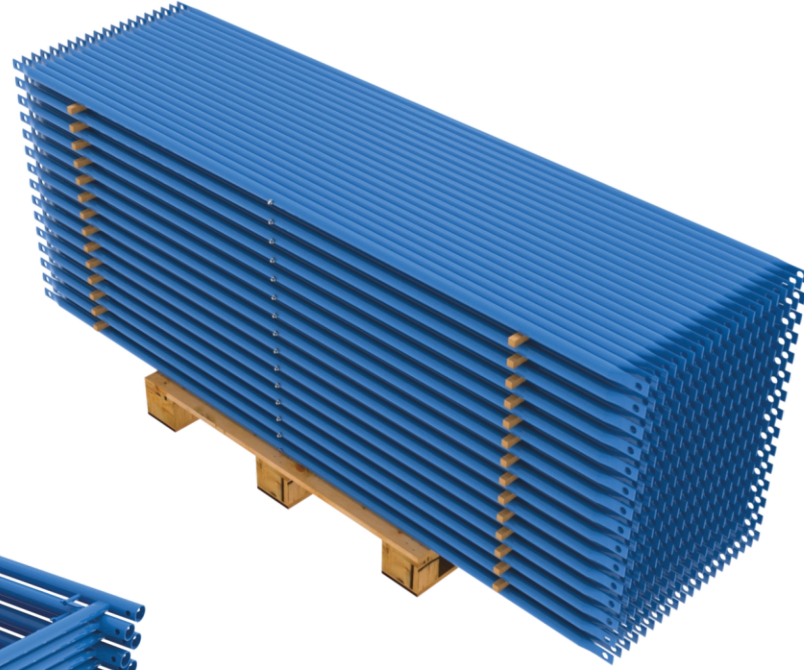

Slabform Çerçeve Paketleme Örneği
Slabform Frame Packing Method

Alt Ayar Mili Ø48 Paketleme Örneği
Base Jack Ø48 Packing Method

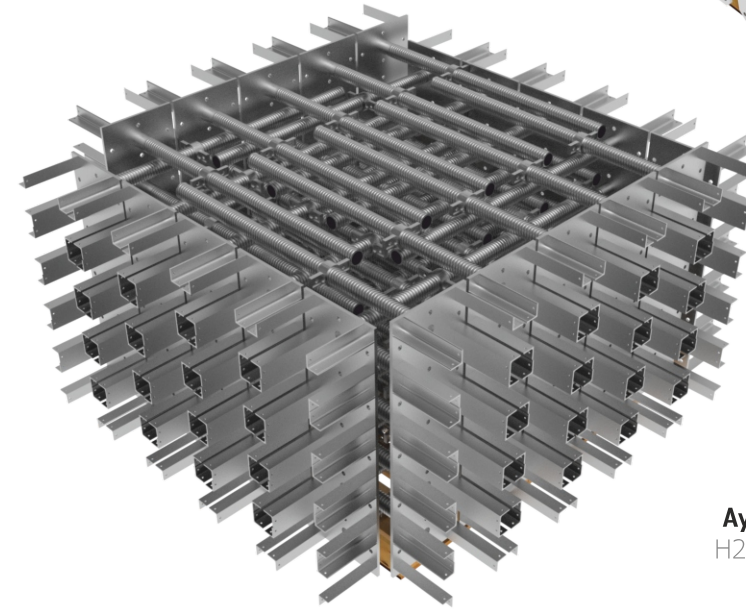
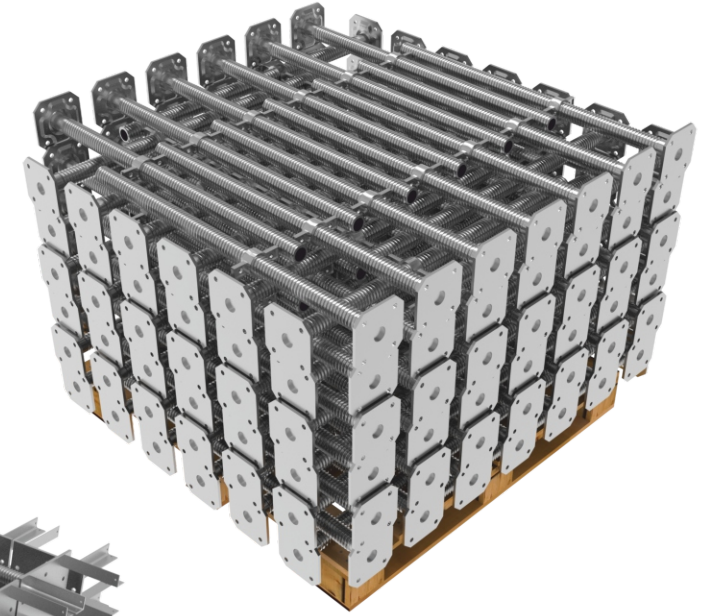

Ayar Mili DYB Ø48 Paketleme Örneği
H20 Head Jack Ø48 Packing Method

Bakım - Onarım ve Depolama Talimatları

- 1 - Malzemelerin tamamının hammaddesi çelik olduğundan su içerisinde ve aşırı nemli ortamlarda bulundurulmamalıdır.
- 2 - Kaplaması veya boyası hasar görmüş malzemelerin uygun kaplama malzemesi ile tamirata mümkündür. Bu tür bir işlem için üretici firmadan danışmanlık desteği alınız.
- 3 - Deforme olmuş ürünlerin düzeltilmesi ve tekrar kullanımı mutlaka yetkili personel gözetiminde yapılmalı, kullanıma uygun hale gelmezse kesinlikle kullanılmamalıdır.
- 4 - Ürünlerin stoklanması, üzeri kapalı ve dış hava koşullarından doğrudan etkilenmeyecek şekilde yapılmalıdır.
- 5 - Dış ortamda depolanan ürünlerin üzeri örtülmelidir (çadır bezi, naylon vs.).
- 6 - Ürünler depolama alanına taşınırken (forklift, kule vinç vs.) mutlaka paketin altından taşınmalıdır.

Maintenance - Repair and Storage Instructions

- 1 - Since almost all of the materials are made of steel, they should not be kept in water and in extremely humid environments.
- 2 - It is possible to repair the damaged coating or paint of materials with suitable coating material. For this kind of procedures, consultancy support is provided by the manufacturer.
- 3 - Repair and reuse of the deformed products must be done under the supervision of authorized personel. If the products are in shape not suitable for using, they must not be used.
- 4 - The storage of the product must be done so that they are not directly affected by outdoor weather conditions.
- 5 - Products stored outside must be covered over (canvas, nylon cover).
- 6 - Products must be transported by being held and carried from under the pack when they are moved to the storage area.

KOD CODE	BOYUT cm SIZE cm	AĞIRLIK kg WEIGHT kg
120101002	150/120	19,50
120103002	150/120	22,60

Ø60*3,0 mm
Ø60*4,0 mm

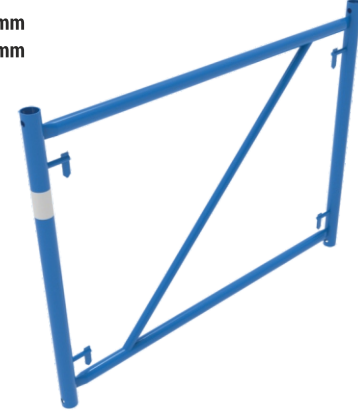

Slabform Çerçeve 150/120
Slabform Frame 150/120

KOD CODE	BOYUT cm SIZE cm	AĞIRLIK kg WEIGHT kg
120201002	150/150	22,10
120203002	150/150	26,10

Ø60*3,0 mm
Ø60*4,0 mm

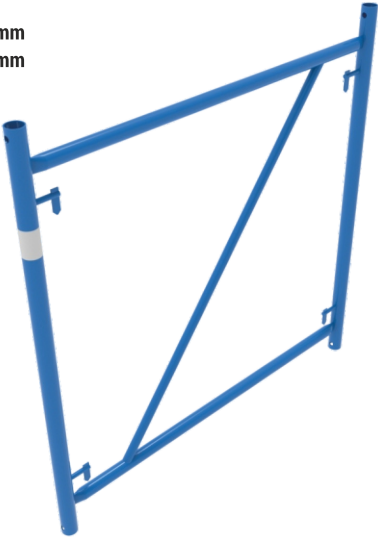

Slabform Çerçeve 150/150
Slabform Frame 150/150

KOD CODE	BOYUT cm SIZE cm	AĞIRLIK kg WEIGHT kg
120301002	150/180	24,80
120303002	150/180	29,50

Ø60*3,0 mm
Ø60*4,0 mm

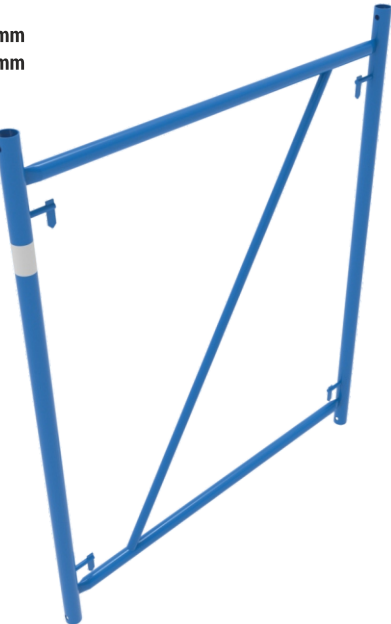

Slabform Çerçeve 150/180
Slabform Frame 150/180

KOD CODE	BOYUT cm SIZE cm	AĞIRLIK kg WEIGHT kg
120401002	150/200	26,40
120403002	150/200	31,70

Ø60*3,0 mm
Ø60*4,0 mm

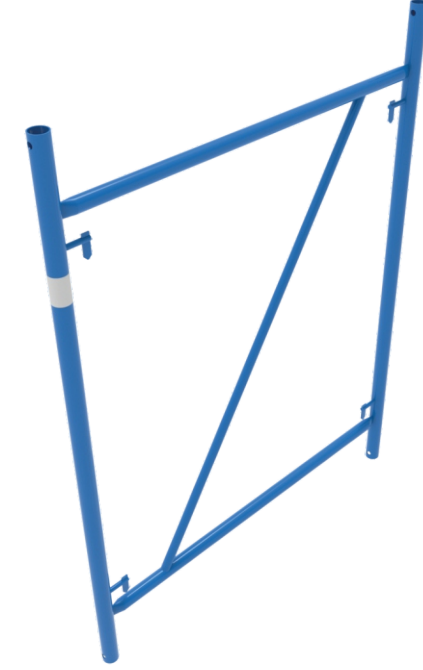

Slabform Çerçeve 150/200
Slabform Frame 150/200

Slabform Çapraz
Slabform Diagonal

KOD CODE	BOYUT cm SIZE cm	AĞIRLIK kg WEIGHT kg
120601002	120/100	4,00
120603002	120/150	5,30
120605002	120/200	6,60
120607002	120/250	8,00
120701002	150/100	4,70
120703002	150/150	5,80
120705002	150/200	7,10
120707002	150/250	8,40
120801002	180-200/100	5,40
120803002	180-200/150	6,40
120805002	180-200/200	7,50
120807002	180-200/250	8,70

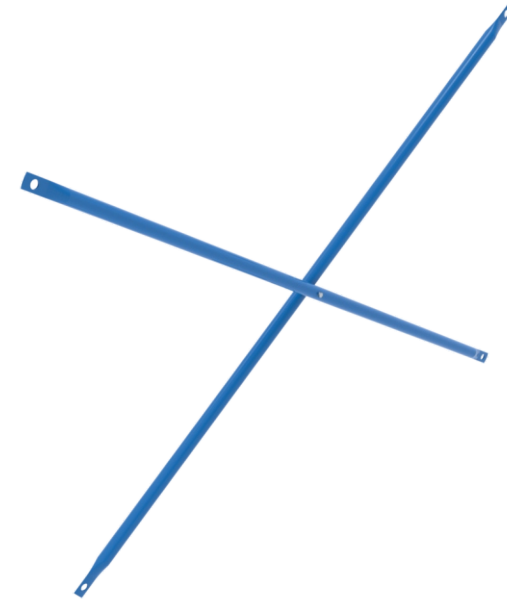

KOD CODE	BOYUT cm SIZE cm	AĞIRLIK kg WEIGHT kg
120900003	080	3,70
120901003	100	4,80
120902003	120	5,80



Ayar Mili Ø48
Jack Ø48

KOD CODE	BOYUT cm SIZE cm	AĞIRLIK kg WEIGHT kg
121000003	080	4,75
121001003	100	6,70
121002003	120	7,70

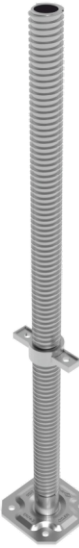

Alt Ayar Mili Ø48
Base Jack Ø48

KOD CODE	BOYUT cm SIZE cm	AĞIRLIK kg WEIGHT kg
121100003	080	9,10
121101003	100	10,20
121102003	120	11,30



Ayar Mili DYB Ø48
H20 Head Jack Ø48

KOD CODE	BOYUT cm SIZE cm	AĞIRLIK kg WEIGHT kg
121201003		4,30



Slabform DYB
Slabform Head-H20

KOD CODE	BOYUT cm SIZE cm	AĞIRLIK kg WEIGHT kg
121203003		1,20



DYB-H20 Bağlama Elemanı Tk.
Head-H20 Coupler

KOD CODE	BOYUT cm SIZE cm	AĞIRLIK kg WEIGHT kg
121302003	40	0,50



Kiriş Bağlama Köşebentisi
Girder Connector

KOD CODE	BOYUT cm SIZE cm	AĞIRLIK kg WEIGHT kg
121401003		0,10



Ayar Mili Kancası
Jack Hook

KOD CODE	BOYUT cm SIZE cm	AĞIRLIK kg WEIGHT kg
121501003		0,50



İskele Ekleme Elemanı Ø60
Scaffold Connection Ø60

KOD CODE	BOYUT cm SIZE cm	AĞIRLIK kg WEIGHT kg
H115P16080	16*80	0,15



Pim ve Kopilya
Pin and Split Pin

KOD CODE	BOYUT cm SIZE cm	AĞIRLIK kg WEIGHT kg
121701001		162,00



Masa Taşıma Arabası
Table Carrier

KOD CODE	BOYUT cm SIZE cm	AĞIRLIK kg WEIGHT kg
121801001		230,00



Masa Taşıma Çatalı
Table Lifting Component

KOD CODE	BOYUT cm SIZE cm	AĞIRLIK kg WEIGHT kg
121901002	145	6,90



Masa Alın Korkuluğu
Slabform Guardrail

KOD CODE	BOYUT cm SIZE cm	AĞIRLIK kg WEIGHT kg
121903002	145	7,20



Masa Alın Korkuluğu Sıkıştırılabilir
Slabform Guardrail Compressible

KOD CODE	BOYUT cm SIZE cm	AĞIRLIK kg WEIGHT kg
121905002	145	8,00



Sıkıştırılabilir Döşeme Korkuluğu
Compressible Slab Guardrail

KOD CODE	BOYUT cm SIZE cm	AĞIRLIK kg WEIGHT kg
300401002	100	2,55
300402002	150	3,70
300403002	200	5,10
300404002	300	7,70
300405002	400	10,20
300407002	600	15,40

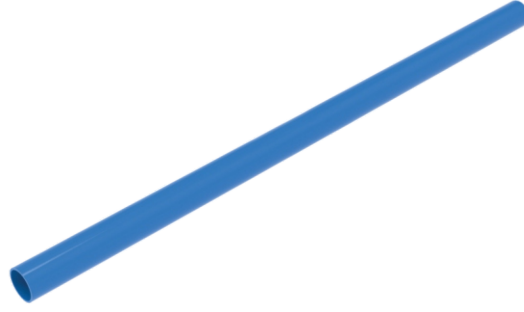

Boru Ø48*2,5
Tube Ø48*2,5

KOD CODE	BOYUT SIZE	AĞIRLIK kg WEIGHT kg
301302023	1,5*1,5	1,00
300502003	1,5*2,0	1,25



Hareketli Kelepçe
Swivel Coupler

KOD CODE	BOYUT cm SIZE cm	AĞIRLIK kg WEIGHT kg
270101005	070	17,50
270102005	090	23,75
270103005	120	30,00
270104005	145	36,25
270105005	170	42,50
270106005	195	48,75
270107005	220	55,00
270108005	245	61,25
270109005	270	67,50
270110005	295	73,75
270111005	320	80,00
270112005	345	86,25
270113005	370	92,50
270114005	395	98,75
270115005	420	105,00
270116005	445	111,25
270117005	470	117,50
270118005	495	123,75
270119005	520	130,00
270120005	545	136,25
270121005	570	142,50
270122005	595	148,75

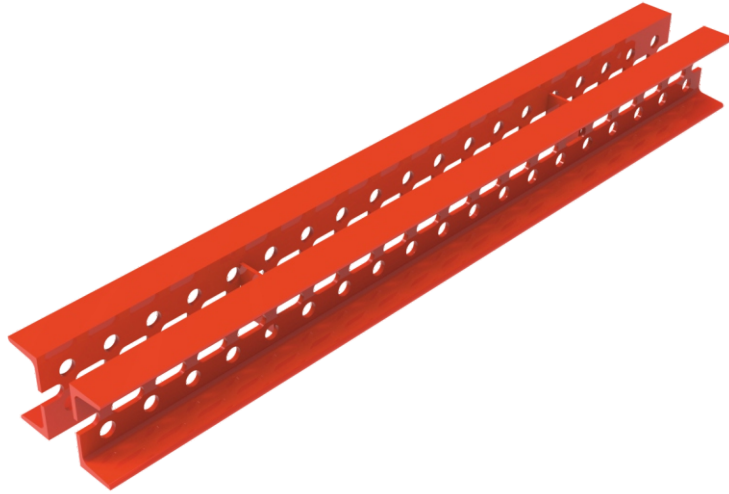

Üniversal Çelik Kuşak
Universal Steel Waler

KOD CODE	BOYUT cm SIZE cm	AĞIRLIK kg WEIGHT kg
270201005	75	13,00

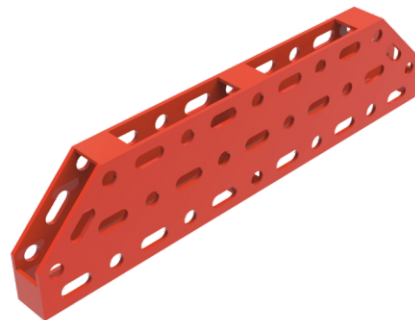

Üniversal Çelik Kuşak Birleştirme Elemanı
Universal Steel Waler Coupler

KOD CODE	BOYUT cm SIZE cm	AĞIRLIK kg WEIGHT kg
270301003		1,00

Üniversal Kuşak Kancası
Universal Waler Hook



Açık Taşıma Sepeti
Storage Cage - Opened Type

KOD CODE	BOYUT cm SIZE cm	AĞIRLIK kg WEIGHT kg
600001001	120*78*83	49,00

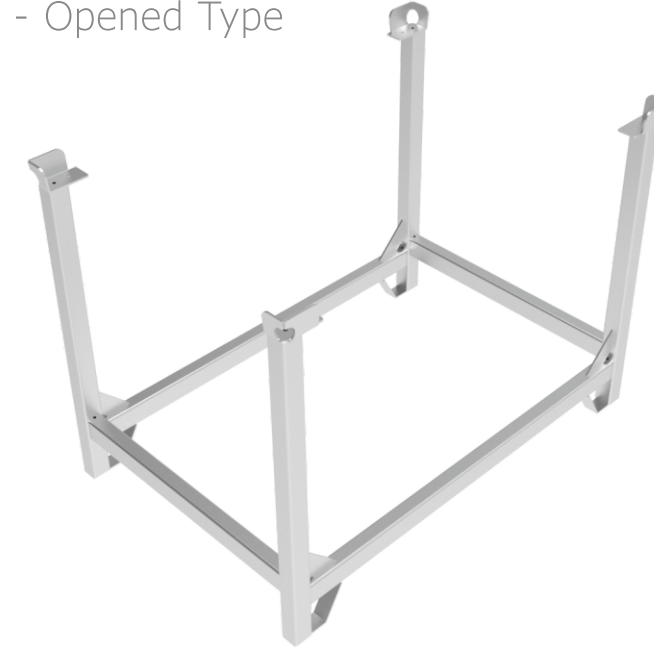

Çesanlı Taşıma Sepeti
Storage Cage - Mesh Type

KOD CODE	BOYUT cm SIZE cm	AĞIRLIK kg WEIGHT kg
600002001	120*78*83	70,00

