

KIN LONG 坚朗

一切为了改善人类居住环境



Luze Tech

坚朗•路泽

Kinlong•Luze

河北路泽新材料科技有限公司

Hebei Luze New Material Technology Co.,Ltd.

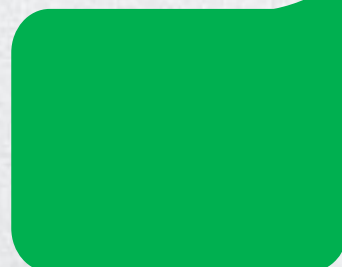

CONTENTS

1

About us

2

Products

3

R&D

4

Quality Control

5

Achievement

01



About us

专业，让建筑更安全

Professionalism makes buildings more secure

About us

KINLONG 坚朗
一切为了改善人类居住环境

坚

朗

五

金

Luze Technology
is a holding subsidiary
of Kinlong Hardware.

专业，让建筑更安全

Professionalism makes buildings more secure

www.kinlong.com



About us

KIN LONG 坚朗

一切为了改善人类居住环境

Unique value can only be created by professionalism,
Speculation has no future



About us

KIN LONG 坚朗

一切为了改善人类居住环境



Stock name: 坚朗五金 (Kinlong Hardware)

Stock code : 002791

- ◆ Kinlong was established in June, 2003.
- ◆ Kinlong became the first listed company in the A-share market in the architectural hardware segmentation field on March 29, 2016.
- ◆ The tenet of Kinlong is **to improve the living environment of human beings.**
- ◆ The strategic goal of Kinlong is to become **the world's largest integrated supplier of building accessories.**



About us

坚朗五金
sz002791



28.00↑

0.24 0.86%
12-12 09:19:39

开盘:0.00

昨收:27.76

最高:0.00

换手:0.00%

成交:0.00万手

市值:99.09亿

最低:0.00

振幅:0.00%

分时

日K

周K

月K





About us

专业，让建筑更安全

Professionalism makes buildings more secure

坚朗 路泽





About us



Luze has a technical cooperation with the research on Chinese architecture on this building. Our product - building isolation rubber bearings are adopted on the first floor of this house.

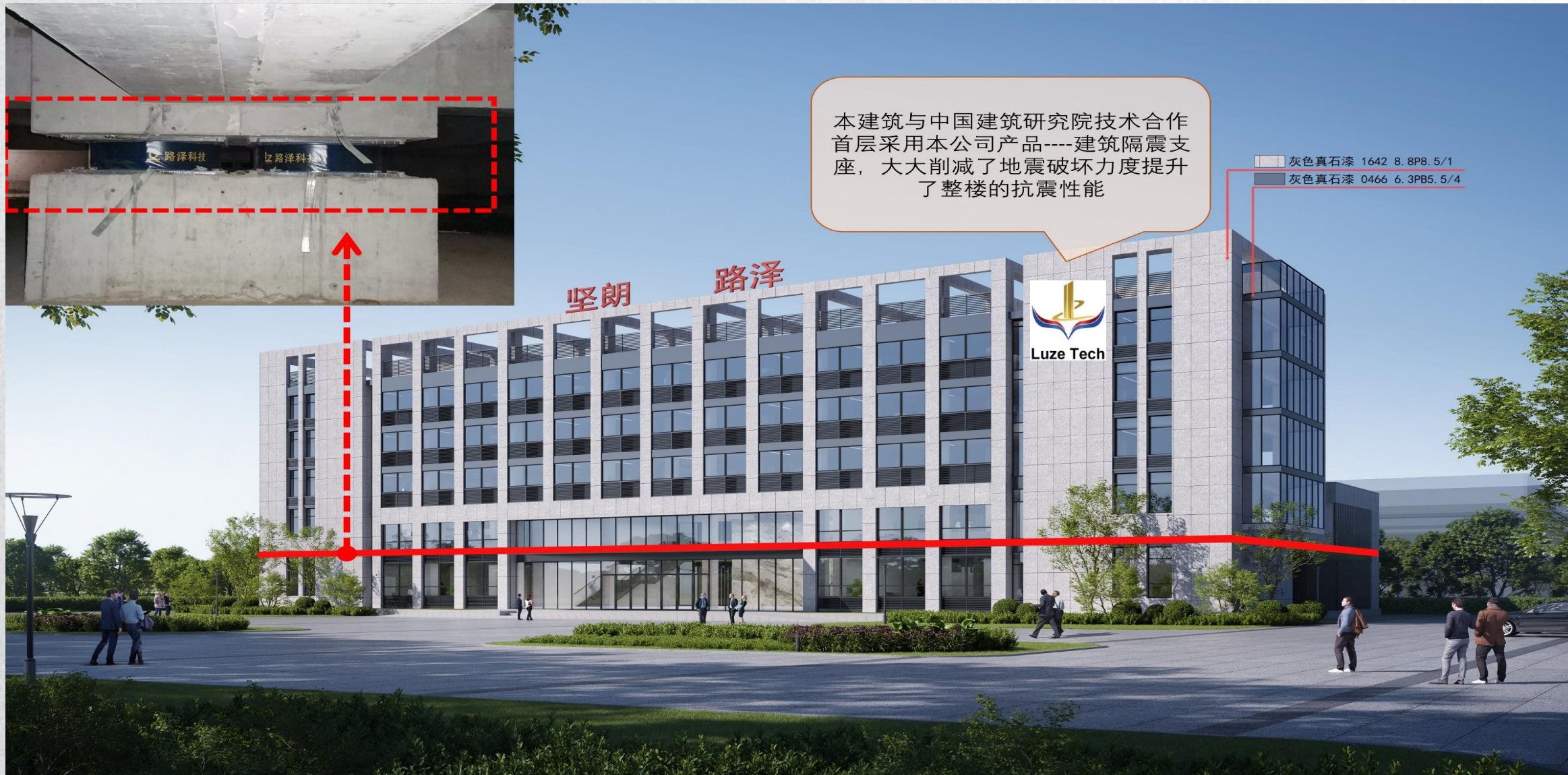



Data Luze



China National High-tech Enterprises

Certification no.:GR202113003409



Covering Area

667000 square meter;



Professional Supplier

**on Seismic isolation & shock absorption products for
Chinese Government's Foreign Aid Projects**



Staffs: 236

Technicist : 22

Administrative staff : 60



BEIJING 2022™



Professional Supplier

**on Seismic isolation & shock absorption products for
Venues of the 2022 Winter Olympics**



Hebei Luze New Materials Technology Co.,Ltd.
Hengshui Luze Metal Products Co.,Ltd.
Yunnan Luze New Materials Technology Co.,Ltd.



Data Luze



China National High-tech Enterprises

Certification no.:GR202113003409



高新技术企业 证书

企业名称：河北路泽新材料科技有限公司

证书编号：GR202113003409

发证时间：2021年12月01日

有效期：三年

批准机关：





Data Luze



The stadium project in Côte d'Ivoire aided by the Chinese government.



The Cape Coast Stadium Project in Ghana aided by the Chinese government.

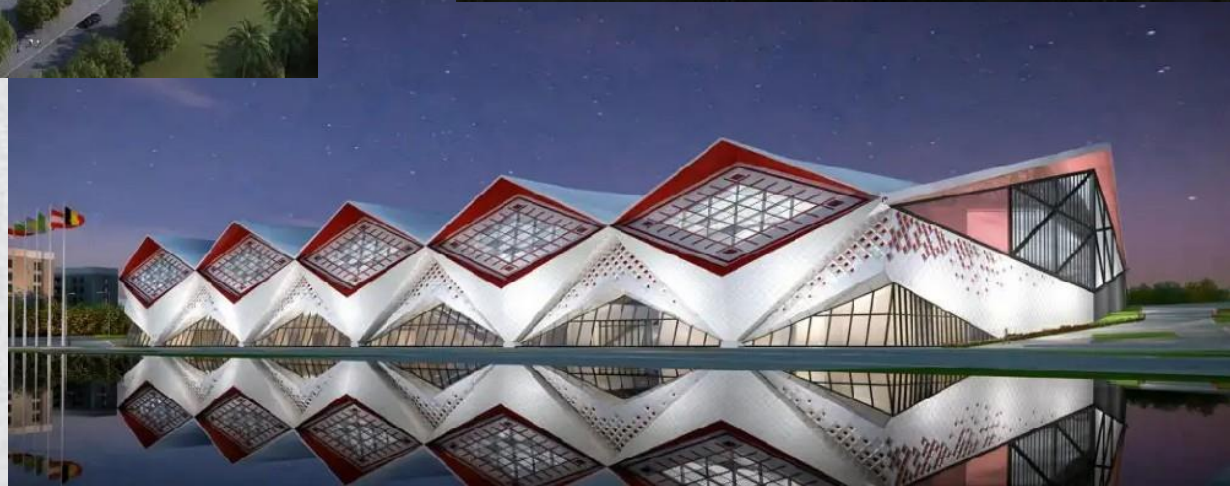

Belarus Standard Swimming Pool Project aided by the Chinese government.



CHINA AID

Professional Supplier

on Seismic isolation & shock absorption products for Chinese Government's Foreign Aid Projects



Data Luze



Professional Supplier

on Seismic isolation & shock absorption products for Venues of the 2022 Winter Olympics



Zhangjiakou Airport



National Speed Skating Oval.

Wukesong Ice Sports Center

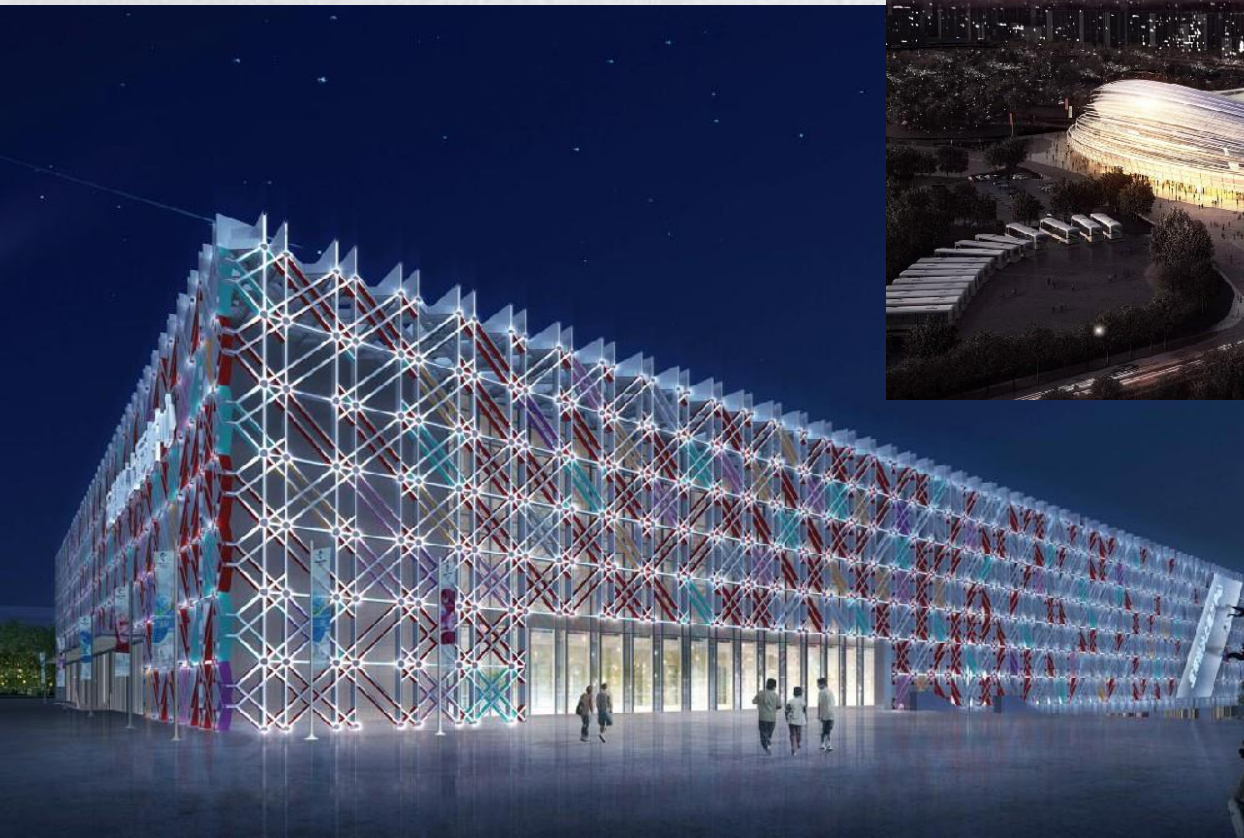



Certificate no.,,
31624E10202R1M

Issuing date:
June 23rd.2021

Valid until:
June 10th.2027

Issuing Organization:
CEOC



职业健康安全管理体系认证证书

证书编号: 31624S10183R1M

兹证明

河北路泽新材料科技有限公司

统一社会信用代码: 91131102MA08HYGP6E

注册地址: 衡水市冀州区高新技术产业开发区南区迎宾路南侧纬一路东侧 邮编: 053010

经营地址: 河北省衡水市高新区北方工业基地迎宾大街10号 邮编: 053010

职业健康安全管理体系符合

GB/T 45001-2020/ISO 45001:2018 标准的要求

该体系认证所覆盖的范围

建筑减隔震支座、屈曲约束支撑、阻尼器、摩擦摆、板式橡胶支座、盆式橡胶支座、球型钢支座的生产和; 伸缩缝、止水带、铅垫板的销售及相关的职业健康安全管理活动

初次发证日期: 2021年06月23日 本次发证日期: 2024年06月11日 证书有效日期: 2027年06月10日

获证组织需每年接受监督审核且满足要求, 证书方可继续有效
认证证书有效性核实请登录下列网站或扫描二维码
国家认证认可监督管理委员会网站 cx.cnca.cn



签发人:



中国认可
国际互认
管理体系
MANAGEMENT SYSTEM
CNAS C265-M

华生原检测认证中心(北京)有限公司

中心地址: 北京市朝阳区北苑路13号院1号楼7层B单元709

中心网站: www.china-eoc.org 电话: 010-52421856



OCCUPATION HEALTH SAFETY MANAGEMENT SYSTEM CERTIFICATE

No.31624S10183R1M

Awarded to

Hebei Luze New Material Technology Co., Ltd

Unified social credit code:91131102MA08HYGP6E

Registration Add:No. 10 Yingbin street, north industrial base, high tech Zone, Hengshui City, Hebei Province

Service Add: No. 10 Yingbin street, north industrial base, high tech Zone, Hengshui City, Hebei Province

The Occupational Health and Safety Management System of the above

GB/T 45001-2020/ISO 45001:2018

Scope of this management Certification

Production of building seismic isolation bearings, buckling restrained supports, dampers, friction pendulums, plate rubber bearings, basin rubber bearings, and spherical steel bearings; Sales of expansion joints, waterstops, lead pads, and related occupational health and safety management activities

Date of Issue: June 23rd,2021

Date of supervision: June 11th,2024

Valid until: June 10th,2027

The certificate is valid after annual supervision

Certificate query approach

National certification and Accreditation Administration: cx.cnca.cn



General
Manager:



中国认可
国际互认
管理体系
MANAGEMENT SYSTEM
CNAS C265-M

CEOC Testing & Certification Center (Beijing)Co.,Ltd.

Address:Room 709,Unit B,Building 1,Yard 13,Beiyuan Road,Chaoyang District,Beijing.

Website:www.china-eoc.org Phone:010-52421856



Certificate no.,.
31624S10183R1M

Issuing date:
June 23rd.2021

Valid until:
June 10th.2027

Issuing Organization:
CEOC

QMS



质量管理体系认证证书

证书编号: 31624Q10383R1M

兹证明

河北路泽新材料科技有限公司

统一社会信用代码: 91131102MA08HYGP6E

注册地址: 衡水市冀州区高新技术产业开发区南区迎宾路南侧纬一路东侧 邮编: 053010

经营地址: 河北省衡水市高新区北方工业基地迎宾大街10号 邮编: 053010

质量管理体系符合

GB/T 19001-2016/ISO 9001:2015 标准的要求

该体系认证所覆盖的范围

建筑减隔震支座、屈曲约束支撑、阻尼器、摩擦摆、板式橡胶支座、盆式橡胶支座、球型钢座的生产; 伸缩缝、止水带、铅垫板的销售

初次发证日期: 2022年05月18日 本次发证日期: 2024年06月11日 证书有效日期: 2027年06月10日

获证组织需每年接受监督审核且满足要求, 证书方可继续有效
认证证书有效性核实请登录下列网站或扫描二维码
国家认证认可监督管理委员会网站 cx.cnca.cn



签发人:



中国认可
国际互认
管理体系
MANAGEMENT SYSTEM
CNAS C265-M

华生原检测认证中心(北京)有限公司

中心地址: 北京市朝阳区北苑路13号院1号楼7层B单元209

中心网站: www.china-eoc.org 电话: 010-52421856



QUALITY MANAGEMENT SYSTEM CERTIFICATE

No. 31624Q10383R1M

Awarded to

Hebei Luze New Material Technology Co., Ltd

Unified social credit code:91131102MA08HYGP6E

Registration Add:No. 10 Yingbin street, north industrial base, high tech Zone, Hengshui City, Hebei Province

Service Add: No. 10 Yingbin street, north industrial base, high tech Zone, Hengshui City, Hebei Province

The Quality Management System of the above organization has been assessed

GB/T 19001-2016/ISO 9001:2015

Scope of this management Certification

Production of building seismic isolation bearings, buckling restrained supports, dampers, friction pendulums, plate rubber bearings, basin rubber bearings, and spherical steel bearings; Sales of expansion joints, waterstops, and lead pads

Date of Issue: May 18th,2022

Date of suprvision: June 11th,2024

Valid until: June 10th,2027

The certificate is valid after annual supervision

Certificate query approach:

National certification and Accreditation Administration: cx.cnca.cn



General
Manager:



中国认可
国际互认
管理体系
MANAGEMENT SYSTEM
CNAS C265-M

CEOC Testing & Certification Center (Beijing)Co.,Ltd.

Address:Room 709,Unit B,Building 1,Yard 13,Beiyuan Road,Chaoyang District,Beijing.

Website:www.china-eoc.org Phone:010-52421856



Certificate no.,,
31624Q10383R1M

Issuing date:
May 18th.2022

Valid until:
June 10th.2027

Issuing Organization:
CEOC



CE-CPR MARK Certification



**Elastomeric Isolator -
Lead Rubber Bearing(LRB)**

ZÚS **TECHNICKÝ A ZKUŠEBNÍ ÚSTAV STAVEBNÍ PRAHA, s.p.**
 Technical and Test Institute for Construction Prague, S0E
 Akreditované laboratoře, Autorizovaná osoba, Oznamovaný subjekt, Subjekt pro technické posuzování, Certifikační orgány,
 Inspekční orgán / Accredited Laboratories, Authorized Body, Notified Body, Technical Assessment Body, Certification Bodies,
 Inspection Body • Prosecká 811/76a, Prosek, 190 00 Praha 9, Czech Republic

Notified Body 1020

**CERTIFICATE
OF CONSTANCY OF PERFORMANCE**

No. 1020 – CPR – 090-068535

In compliance with Regulation 305/2011/EU of the European Parliament and of the Council of 9 March 2011 (the Construction Products Regulation or CPR), this certificate applies to the construction product:

Anti-seismic devices
 Variant: Elastomeric isolators
 Type: Lead rubber bearings (LRB)

placed on the market under the name or trade mark of

Hebei Luze New Material Technology Co., Ltd
 Identification No.: 91131102MA08HYGP6E
 Address: South of Yingbin Road, East of Weiyi Road, Southern Industrial District, High-tech Industrial Development Zone, Jizhou District, Hengshui City, Hebei Province/ P.R. China

and produced in the manufacturing plant:

Hebei Luze New Material Technology Co., Ltd
 Identification No.: 91131102MA08HYGP6E
 Address: South of Yingbin Road, East of Weiyi Road, Southern Industrial District, High-tech Industrial Development Zone, Jizhou District, Hengshui City, Hebei Province/ P.R. China

This certificate attests that all provisions concerning the assessment and verification of constancy of performance described in Annex ZA of the standard

EN 15129:2009

under system 1 for the performance set out in this certificate are applied and that the factory production control conducted by the manufacturer is assessed to ensure the

constancy of performance of the construction product.

This certificate was first issued on 11th February 2026 and will remain valid as long as neither the harmonised standard, the construction product, the AVCP methods nor the manufacturing conditions in the plant are modified significantly, unless suspended or withdrawn by the notified product certification body.

The stamp of the Notified Body 1020
 Prague, 11th February 2026

 Martin Pešek
 Deputy Manager of the Notified Body



Certificate no.,
1020-CPR-090-068536

Issuing date:
Feb 11th. 2026

Issuing Organization:
TZUS



CE-CPR MARK Certification



**Elastomeric Isolator -
High Damping Rubber Bearing(HDR)**



Certificate no.,
1020-CPR-090-068537

Issuing date:
Feb 11th. 2026

Issuing Organization:
TZUS

ZÚS [®] **TECHNICKÝ A ZKUŠEBNÍ ÚSTAV STAVEBNÍ PRAHA, s.p.**
Technical and Test Institute for Construction Prague, SOE
Akreditované laboratoře, Autorizovaná osoba, Oznamovaný subjekt, Subjekt pro technické posuzování, Certifikační orgány,
 Inspekční orgán / Accredited Laboratories, Authorized Body, Notified Body, Technical Assessment Body, Certification Bodies,
 Inspection Body • Prosecká 811/76a, Prošek, 190 00 Praha 9, Czech Republic

Notified Body 1020

**CERTIFICATE
OF CONSTANCY OF PERFORMANCE**

No. 1020 – CPR – 090-068537

In compliance with Regulation 305/2011/EU of the European Parliament and of the Council of 9 March 2011 (the Construction Products Regulation or CPR), this certificate applies to the construction product:

Anti-seismic devices
 Variant: Elastomeric isolators
 Type: High Damping Rubber Bearing (HDRB)

placed on the market under the name or trade mark of

Hebei Luze New Material Technology Co., Ltd
 Identification No.: 91131102MA08HYGP6E
 Address: South of Yingbin Road, East of Weiyei Road, Southern Industrial District, High-tech Industrial Development Zone, Jizhou District, Hengshui City, Hebei Province/ P.R. China

and produced in the manufacturing plant:

Hebei Luze New Material Technology Co., Ltd
 Identification No.: 91131102MA08HYGP6E
 Address: South of Yingbin Road, East of Weiyei Road, Southern Industrial District, High-tech Industrial Development Zone, Jizhou District, Hengshui City, Hebei Province/ P.R. China

This certificate attests that all provisions concerning the assessment and verification of constancy of performance described in Annex ZA of the standard

EN 15129:2009

under system 1 for the performance set out in this certificate are applied and that the factory production control conducted by the manufacturer is assessed to ensure the

constancy of performance of the construction product.

This certificate was first issued on 11th February 2026 and will remain valid as long as neither the harmonised standard, the construction product, the AVCP methods nor the manufacturing conditions in the plant are modified significantly, unless suspended or withdrawn by the notified product certification body.

The stamp of the Notified Body 1020
 Prague, 11th February 2026

Martin Pešek
 Deputy Manager of the Notified Body



CE-CPR MARK Certification

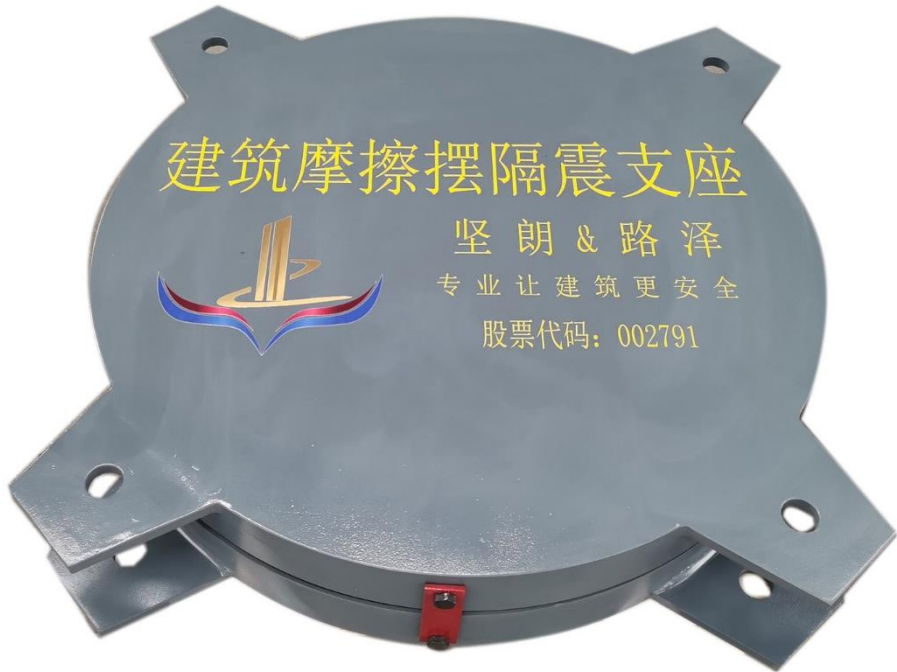

**Curved Surface Sliders-
Friction Pendulum Type(FPS)**

ZÚS **® TECHNICKÝ A ZKUŠEBNÍ ÚSTAV STAVEBNÍ PRAHA, s.p.**
Technical and Test Institute for Construction Prague, S0E
Akreditované laboratorie, Autorizovaná osoba, Oznamovaný subjekt, Subjekt pro technické posuzování, Certifikační orgány, Inspekční orgán / Accredited Laboratories, Authorized Body, Notified Body, Technical Assessment Body, Certification Bodies, Inspection Body • Prosecká 811/76a, Prosek, 190 00 Praha 9, Czech Republic

Notified Body 1020

**CERTIFICATE
OF CONSTANCY OF PERFORMANCE**

No. 1020 – CPR – 090-068539

In compliance with Regulation 305/2011/EU of the European Parliament and of the Council of 9 March 2011 (the Construction Products Regulation or CPR), this certificate applies to the construction product:

Anti-seismic devices
 Variant: Curved Surface Sliders
 Type: Friction Pendulum

placed on the market under the name or trade mark of

Hebei Luze New Material Technology Co., Ltd
 Identification No.: 91131102MA08HYGP6E
 Address: South of Yingbin Road, East of Weyi Road, Southern Industrial District, High-tech Industrial Development Zone, Jizhou District, Hengshui City, Hebei Province/ P.R. China

and produced in the manufacturing plant:

Hebei Luze New Material Technology Co., Ltd
 Identification No.: 91131102MA08HYGP6E
 Address: South of Yingbin Road, East of Weyi Road, Southern Industrial District, High-tech Industrial Development Zone, Jizhou District, Hengshui City, Hebei Province/ P.R. China

This certificate attests that all provisions concerning the assessment and verification of constancy of performance described in Annex ZA of the standard

EN 15129:2009

under system 1 for the performance set out in this certificate are applied and that the factory production control conducted by the manufacturer is assessed to ensure the

constancy of performance of the construction product.

This certificate was first issued on 11th February 2026 and will remain valid as long as neither the harmonised standard, the construction product, the AVCP methods nor the manufacturing conditions in the plant are modified significantly, unless suspended or withdrawn by the notified product certification body.

The stamp of the Notified Body 1020
 Prague, 11th February 2026

 Martin Pešek
 Deputy Manager of the Notified Body



Certificate no.,
1020-CPR-090-068539

Issuing date:
Feb 11th. 2026

Issuing Organization:
TZUS



CE-CPR MARK Certification



Fluid Viscous Damper(FVD)

ZÚS [®] **TECHNICKÝ A ZKUŠEBNÍ ÚSTAV STAVEBNÍ PRAHA, s.p.**
Technical and Test Institute for Construction Prague, SOE
Akreditované laboratoře, Autorizovaná ceoba, Oznamení subjekt, Subjekt pro technické posuzování, Certifikační orgány, Inspekční orgán / Accredited Laboratories, Authorized Body, Notified Body, Technical Assessment Body, Certification Bodies, Inspection Body • Prosecká 811/76a, Prosek, 190 00 Praha 9, Czech Republic

Notified Body 1020

**CERTIFICATE
 OF CONSTANCY OF PERFORMANCE**

No. 1020 – CPR – 090-068541

In compliance with Regulation 305/2011/EU of the European Parliament and of the Council of 9 March 2011 (the Construction Products Regulation or CPR), this certificate applies to the construction product:

Anti-seismic devices
 Variant: Fluid Viscous Dampers (FVD)

placed on the market under the name or trade mark of

Hebei Luze New Material Technology Co., Ltd
 Identification No.: 91131102MA08HYGP6E
 Address: South of Yingbin Road, East of Weiyi Road, Southern Industrial District, High-tech Industrial Development Zone, Jizhou District, Hengshui City, Hebei Province/ P.R. China

and produced in the manufacturing plant:

Hebei Luze New Material Technology Co., Ltd
 Identification No.: 91131102MA08HYGP6E
 Address: South of Yingbin Road, East of Weiyi Road, Southern Industrial District, High-tech Industrial Development Zone, Jizhou District, Hengshui City, Hebei Province/ P.R. China

This certificate attests that all provisions concerning the assessment and verification of constancy of performance described in Annex ZA of the standard

EN 15129:2009

under system 1 for the performance set out in this certificate are applied and that the factory production control conducted by the manufacturer is assessed to ensure the

constancy of performance of the construction product.

This certificate was first issued on 11th February 2026 and will remain valid as long as neither the harmonised standard, the construction product, the AVCP methods nor the manufacturing conditions in the plant are modified significantly, unless suspended or withdrawn by the notified product certification body.

The stamp of the Notified Body 1020
 Prague, 11th February 2026

 **Martin Pešek**
 Deputy Manager of the Notified Body



Certificate no.,
1020-CPR-090-068541

Issuing date:
Feb 11th. 2026

Issuing Organization:
TZUS

02



Services & solutions



Services & solutions

01



Seismic Isolation Device
Service Solution



02



Energy Dissipation Device
Service Solution

03



Seismic Control Product
Service solution



Services & solutions

Seismic Isolation Device

LNR

Linear Natural Rubber bearing



HDR

High Damping Rubber bearing

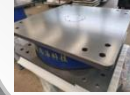

LRB

Lead rubber bearing



FPB/FPS

Friction Pendulum System/
Friction Pendulum isolation bearing

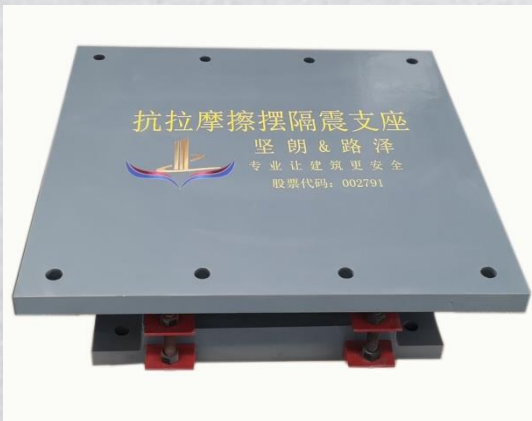
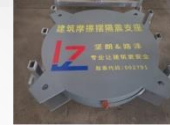



Services & solutions

Seismic Isolation Product



LNR Linear Natural Rubber bearing



It can isolate about 80% of the seismic force (the seismic performance of isolated buildings is approximately 8 to 10 times that of traditional buildings), ensuring the normal use function of the building as much as possible. .



It is applicable to all isolated buildings, including but not limited to the following situations:

Lifeline projects:

Schools, kindergartens, hospitals, elderly care institutions, children's welfare institutions, emergency command centers, emergency shelters, radio and television, etc.

Major projects:

Airport terminals, museums, exhibition halls, stadiums, LNG (liquefied natural gas) storage tanks, nuclear power plants, etc.

Prefabricated building structures, seismic reinforcement and renovation projects, etc.



Services & solutions

Seismic Isolation Product



LRB

Lead Rubber Bearing

Isolation bearings can extend the natural vibration period of the structure and increase the structural damping. They can isolate about 80% of the seismic force (the seismic performance of isolated buildings is approximately 8 to 10 times that of traditional buildings), ensuring the normal use function of the building as much as possible. .

It is applicable to all isolated buildings, including but not limited to the following situations:

Lifeline projects:

Schools, kindergartens, hospitals, elderly care institutions, children's welfare institutions, emergency command centers, emergency shelters, radio and television, etc.

Major projects:

Airport terminals, museums, exhibition halls, stadiums, LNG (liquefied natural gas) storage tanks, nuclear power plants, etc.

Prefabricated building structures, seismic reinforcement and renovation projects, etc.





Services & solutions

Seismic Isolation Product

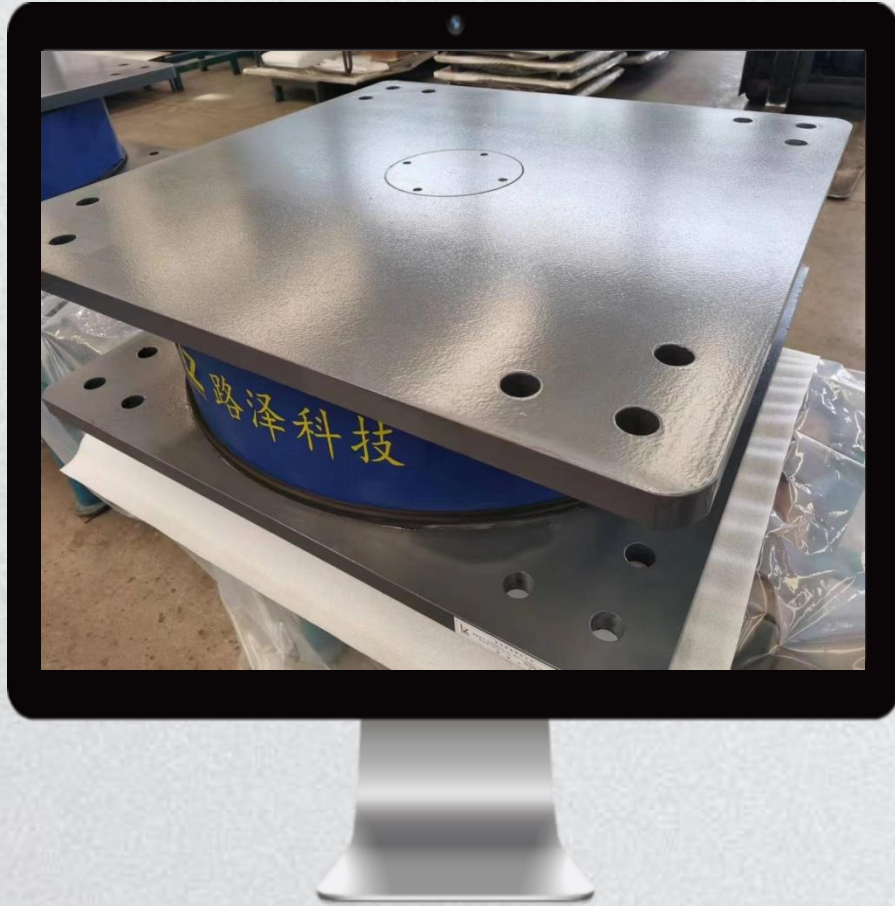

HDR High Damping Rubber bearing



Isolation bearings can extend the natural vibration period of the structure and increase the structural damping. They can isolate about 80% of the seismic force (the seismic performance of isolated buildings is approximately 8 to 10 times that of traditional buildings), ensuring the normal use function of the building as much as possible. .

It is applicable to all isolated buildings, including but not limited to the following situations:

Lifeline projects:

Schools, kindergartens, hospitals, elderly care institutions, children's welfare institutions, emergency command centers, emergency shelters, radio and television, etc.

Major projects:

Airport terminals, museums, exhibition halls, stadiums, LNG (liquefied natural gas) storage tanks, nuclear power plants, etc.

Prefabricated building structures, seismic reinforcement and renovation projects, etc.



Services & solutions

Seismic Isolation Product



FPB/FPS Friction Pendulum System/ Friction Pendulum isolation bearing

Some advantages of friction pendulum isolation bearings are as follows:

It has stable hysteretic performance and excellent durability. It boasts high reliability under the influence of factors such as temperature and long-term loads.

The period of the superstructure can be controlled. It can adjust the lateral stiffness by itself and reset automatically.

The vibration period is independent of the mass carried by the structure.

It is applicable to all isolated buildings, including but not limited to the following situations:

Lifeline projects:

Schools, kindergartens, hospitals, elderly care institutions, children's welfare institutions, emergency command centers, emergency shelters, radio and television, etc.

Major projects:

Airport terminals, museums, exhibition halls, stadiums, LNG (liquefied natural gas) storage tanks, nuclear power plants, etc.

Prefabricated building structures, seismic reinforcement and renovation projects, etc.



Services & solutions

Vibration Damping Product

VFD

Viscous Fluid Damper



MYD

Metal Yielding Dampers



BRB

Buckling-Restrained Braces



FD

Frictional Dampers

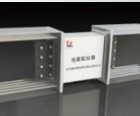

CBD

Coupling Beam Dampers

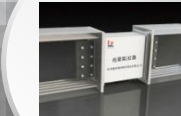

Services & solutions

Vibration Damping Product



VFD

Viscous Fluid Damper



It can effectively consume energy, reduce the seismic and wind-induced vibration responses of buildings, and has wide engineering applicability. When an earthquake occurs, the damper maximally absorbs and consumes the impact energy of the earthquake on the building structure, greatly alleviating the impact and damage caused by the earthquake to the building structure, which is equivalent to installing a "safety airbag" on the building or bridge.

Seismic resistance of building structures: When an earthquake occurs, the damper maximally absorbs and consumes the impact energy of the earthquake on the building structure, alleviates the impact and damage caused by the earthquake to the building structure, and ensures the safety of the building. Structural vibrations caused by earthquakes, wind-induced vibrations, moving loads, and dynamic equipment, multi-story and high-rise buildings in various intensity zones.



Services & solutions

Vibration Damping Product



BRB

Buckling-Restrained Braces



It has the characteristics of strong energy dissipation capacity and excellent hysteretic performance. On the one hand, buckling-restrained braces can avoid the defect of significant difference in tensile and compressive bearing capacity of ordinary braces. On the other hand, it has the energy dissipation capacity of a metal damper and can act as a "fuse" in the structure, making the main structure basically within the elastic range.

BRB is often used in large-span and heavy-load structures to add stiffness to the structure, such as in new main structures and reinforcements of hospitals, schools, airports, covered playgrounds, high-rise buildings, stadiums, airports and stations, cultural and health facilities, exhibition centers, industrial plants, etc.



Services & solutions

Vibration Damping Product



MYD

Metal Yielding Dampers



Metal yield-type dampers utilize the high energy dissipation characteristics of steel and adopt soft steel with low yield strength and high ductility as the core material of the dampers. They use the inelastic characteristics of special soft steel plates after yielding to dissipate the energy input from earthquakes and other external sources into the structure.



The seismic (vibration) performance is not affected by temperature and it is currently a more cost-effective product among various types of energy dissipation and shock absorption devices.



It can be used in various structural forms
New buildings, shock absorption and reinforcement, concrete structures, steel structures and heavy wood structures, etc.

Projects

Civil buildings, commercial and public buildings, industrial plant buildings, lifeline projects, etc.



Services & solutions

Vibration Damping Product



FD

Frictional Dampers



A kind of damper that dissipates seismic energy by converting friction force into heat energy through the mutual friction between polymer composite friction materials and friction steel plates, belonging to the displacement-dependent energy dissipation and shock absorption device.



Civil buildings

Such as multi-story and high-rise and large-span building structures of residences, office buildings, shopping malls, etc.;



Lifeline projects

Such as hospitals, schools, urban functional buildings, etc.;

Industrial buildings

Such as factories, towers, equipment, etc.;



Services & solutions

Vibration Damping Product



CBD

Coupling Beam Dampers



The coupling beam damper, which is installed at the position of the coupling beam, is used to replace the traditional concrete coupling beam in the concrete coupled shear wall. It can greatly improve the ductility and energy dissipation capacity of the coupling beam.



The coupling beam damper has many advantages, such as controllable yield bearing capacity, easy replacement after an earthquake, no occupation of the usable space, and excellent seismic performance. In residential projects adopting the concrete shear wall structural system, it is widely applied.



Services & solutions

Vibration Damping Product

Spherical Steel bearings

Pot-type bearings,

VFW

Viscous Damping Walls

Steel Structure bearings





Services & solutions

Vibration Damping Product



Lead Viscoelastic Dampers



VFW Viscous fluid Walls



Services & solutions

Vibration Damping Product

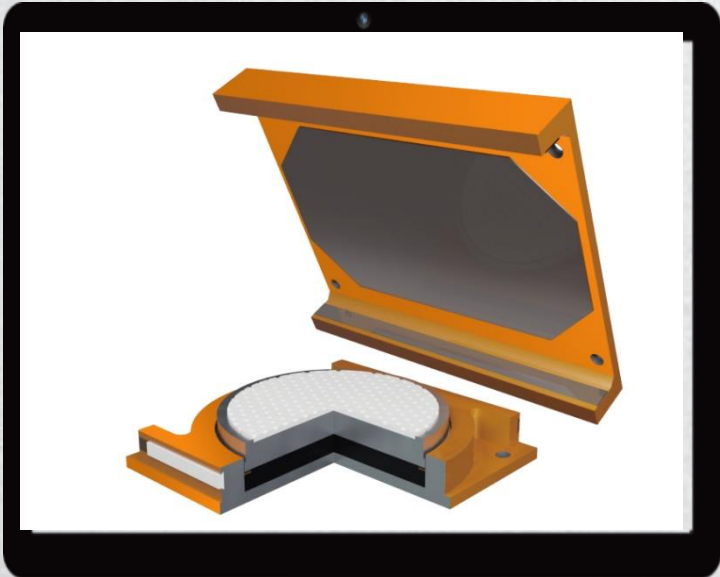

Pot-type bearings,

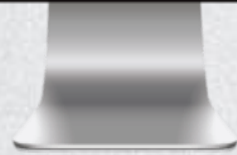

Spherical Steel bearings



Steel Structure bearings

Services & solutions

Seismic Control Product

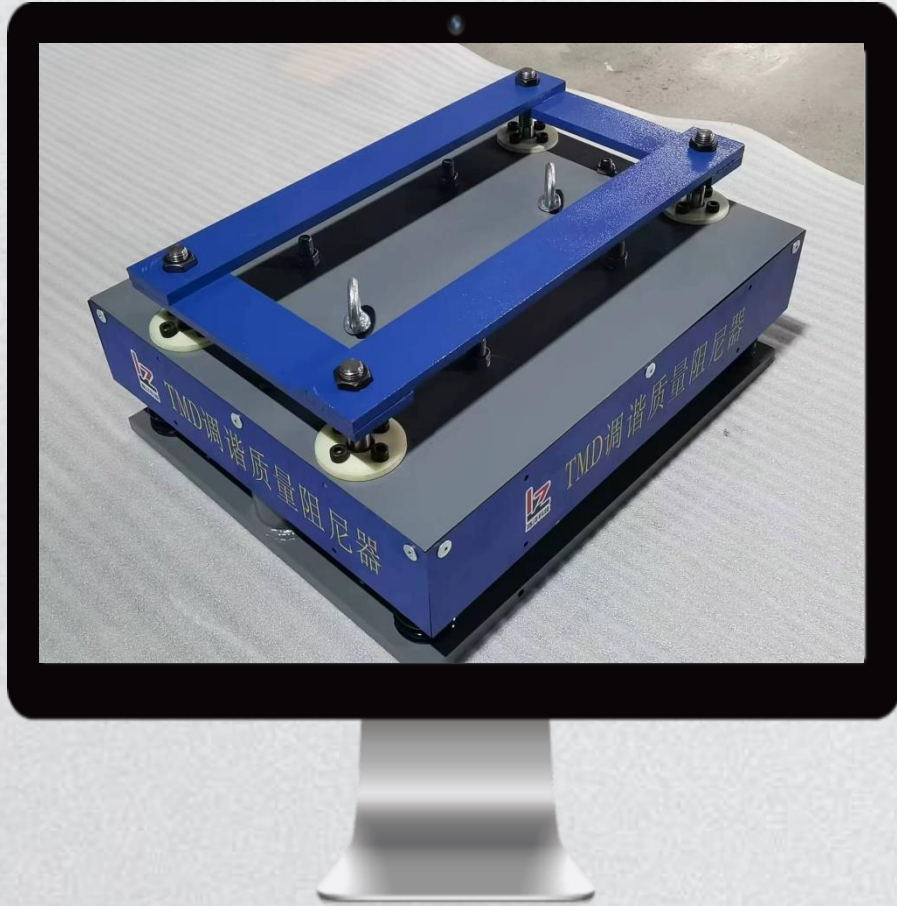

TMD

Tuned Mass Dampers



It is generally supported or suspended on the structure. When the structure vibrates under the external excitation, it drives the TMD system to vibrate together. The inertia force generated by the TMD system reacts on the structure. Tune this inertia force to make it have a coordinating effect on the vibration of the main structure, thereby reducing the dynamic response of the structure, improving the comfort of the structure, and reducing the fatigue damage of the structure. Currently, the widely used damping units include viscous damping units and eddy current damping units..



Tall structures

Such as sightseeing towers, skyscrapers, TV stations, chimneys, etc.



Long-span structures

Such as pedestrian bridges, sports grandstands, large bridges, etc.

Floors in special buildings

Mechanical and electrical plants, gymnasium floors, etc.

Services & solutions

Seismic bracing and suspension brackets

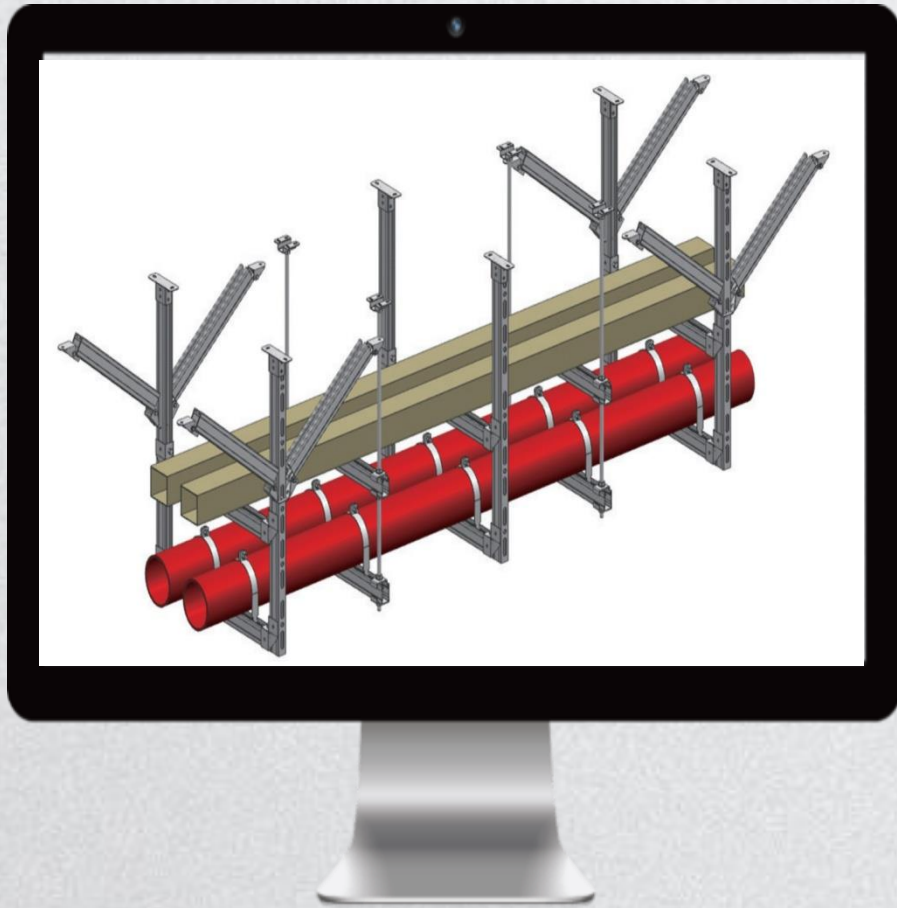

Seismic bracing and suspension brackets



Seismic bracing and suspension systems are support and suspension products used to support mechanical and electrical pipeline equipment such as water pipes, air ducts, cable trays, etc., and provide seismic support. They are firmly connected to the building structure and are seismic support facilities with seismic forces as the main load.

Seismic bracing and suspension systems can resist the impact of earthquakes in both the longitudinal and lateral directions, and can minimize the damage to equipment and the destruction to people's lives and property under unpredictable natural disasters such as earthquakes. Seismic bracing and suspension systems can also better cope with sudden accidents such as earthquakes (secondary disasters) and reduce the damage to equipment. It can be said that seismic bracing and suspension systems can effectively avoid secondary disasters caused by earthquakes.

For the building mechanical and electrical engineering in areas where the seismic fortification intensity is 6 degrees or above, seismic design must be carried out;

Pipeline systems for domestic water supply, fire protection, heating, air-conditioning water, etc., with a nominal diameter larger than DN65;
Equipment with a gravity greater than 1.8KN in suspended pipelines or suspended pipelines with hanging rods whose calculated length exceeds 300mm;

Electrical conduits with an inner diameter of not less than 60mm;
Cable trays, cable troughs, busways with a gravity of not less than 150N/m;

Ventilation, air-conditioning and other systems with a rectangular cross-sectional area of not less than 0.38 square meters and a circular diameter of not less than 0.7m;

All air ducts for smoke prevention and exhaust, air ducts for accident ventilation and related equipment;

Gas pipelines with an inner diameter of not less than 25mm;

In buildings with a height greater than 50m, seismic supports should be set up for gas pipelines;

Common antennas installed on the roof, etc.

03



R&D

专业，让建筑更安全

Professionalism makes buildings more secure

R&D

The leaders of the company took a commemorative photo with Academician Zhou Fulin (2nd Left), an expert in engineering structure and earthquake resistance and disaster mitigation.





R&D

Finite element stress analysis of compression, tension and shear.

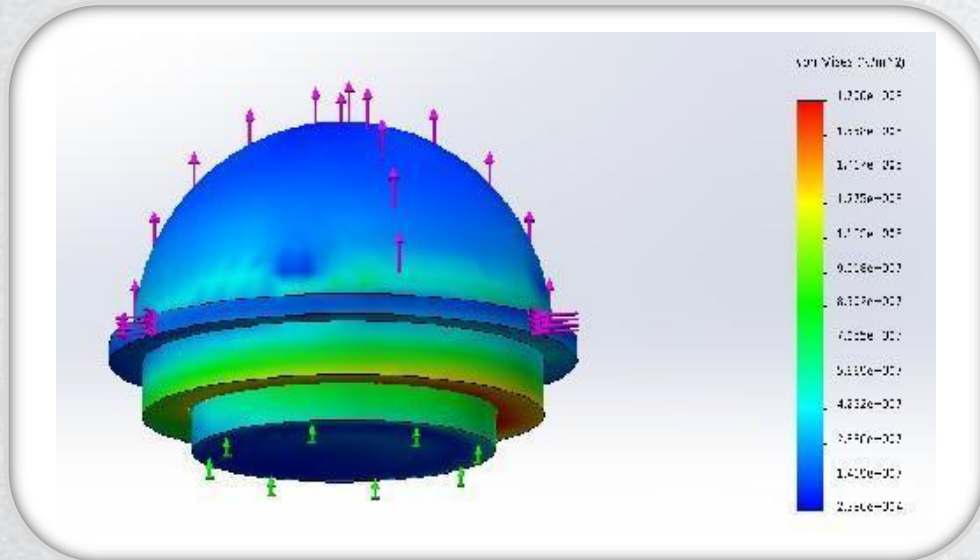

• Analysis of the tension-shear working condition of the anti-seismic spherical steel bearing (with structure).

Analysis of the compression-shear working condition of the anti-seismic spherical steel bearing (with structure). •••

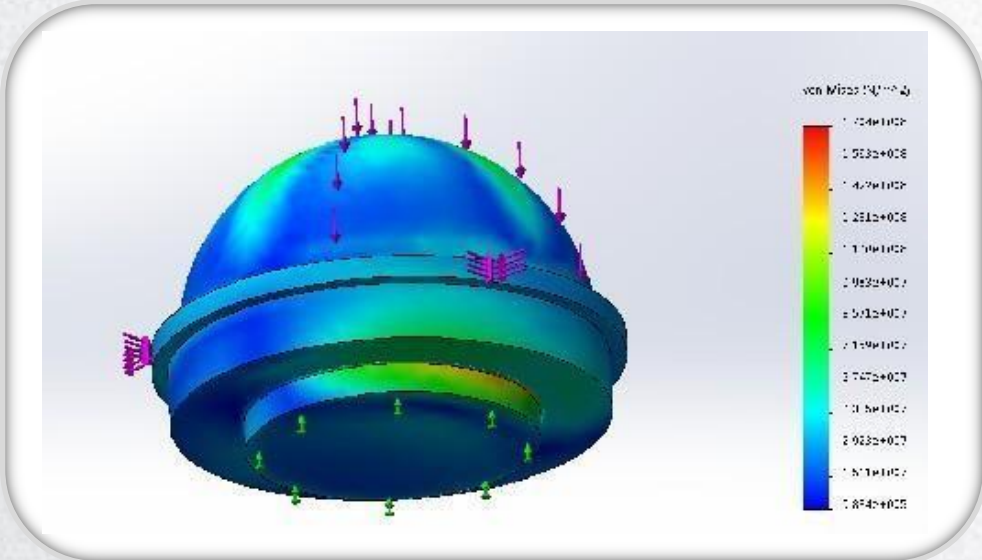



R&D

Finite element stress analysis of compression, tension and shear.

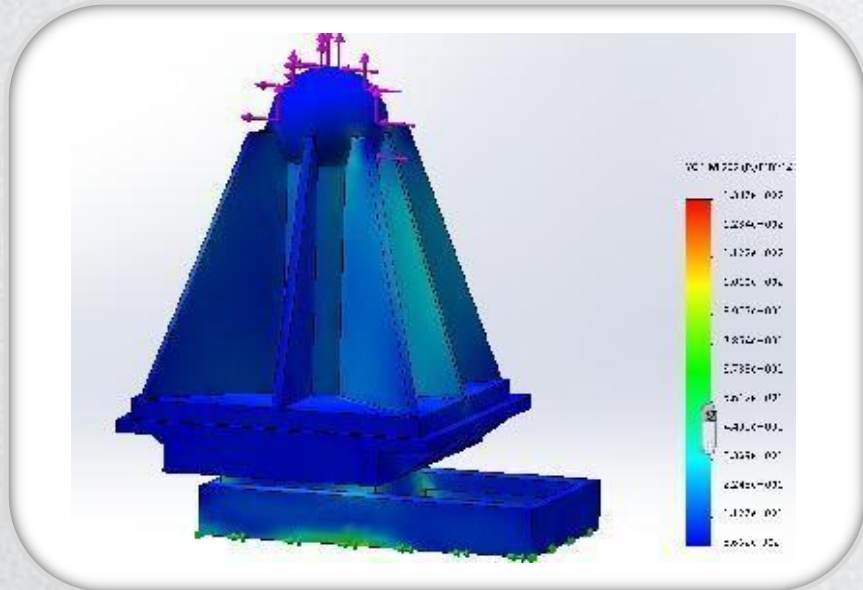

• Analysis of the Tension-Shear Working Condition of the Anti-seismic Spherical Steel Bearing (with Structure).

Analysis of the compression-shear working condition of the anti-seismic spherical steel bearing (with structure).

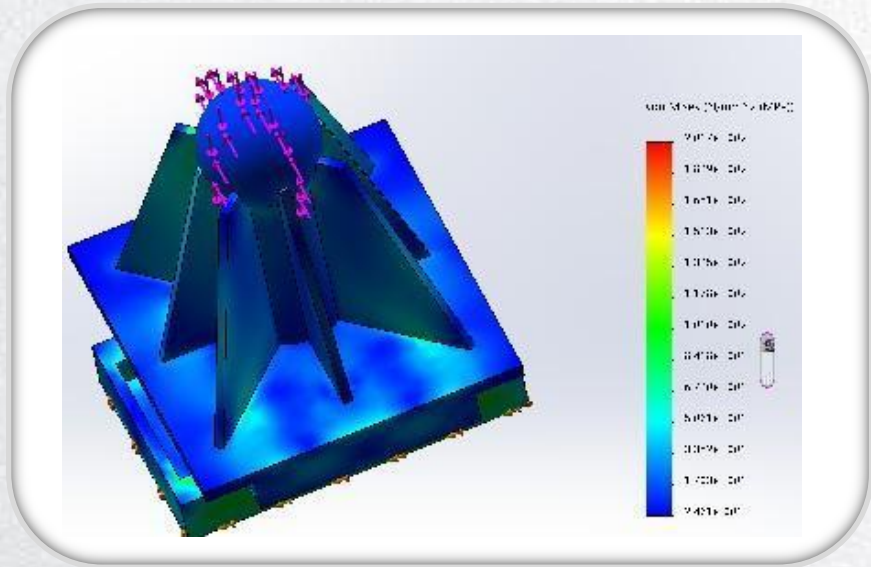



R&D

Finite element stress analysis of compression, tension and shear.



Hebei Luze has a professional R & D team, which can conduct finite element analysis (with structures) on seismic isolation and reduction products, making the product design more reasonable and the building structures safer.

Patent





Quality Control

专业，让建筑更安全

Professionalism makes buildings more secure



Quality Control

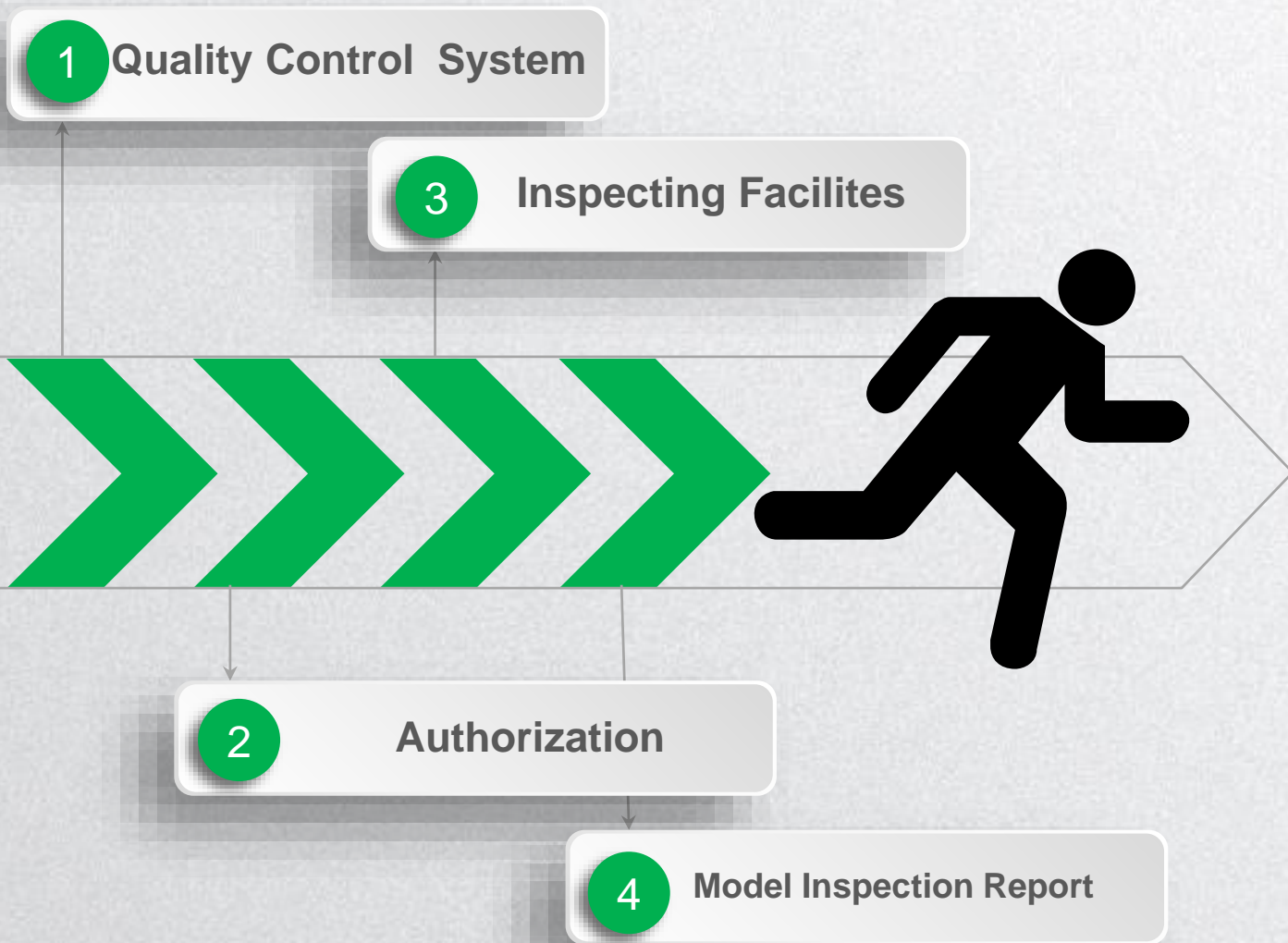

Quality Control System

Dynamic servo test and inspection machine for dampers.





Inspecting Facilities



Dynamic servo pressure-shear testing machine for bearings.





Authorization

生产授权证书

Production Authorization Certificate

发证日期: 2022年03月30日 证书编号: FHCC-CEST-HDR202217

根据交通运输行业标准《公路桥梁高阻尼隔震橡胶支座》和《科技成果授权及监管办法》的相关文件规定,在对你公司生产下述产品的检查中,各项指标均符合交通产品标准和技术质量要求,特颁发此生产授权证书。

公司名称: 河北路泽新材料科技有限公司
 工厂地址: 河北省衡水市高新区北方工业基地迎宾大街10号
 产品名称: HDR系列公路桥梁高阻尼隔震橡胶支座
 有效日期: 2022.03.30-2023.03.29

授权模式: 生产授权+质量年审

中交第一公路勘察设计研究院有限公司
CCCC FIRST HIGHWAY CONSULTANTS CO.,LTD.

西安中交土木科技有限公司
CCCC CIVIL ENGINEERING SCIENCE & TECHNOLOGY CO.,LTD.

可经<http://app.vcivil.com>查询证书真伪

授权书

证书编号: KSGF-QLZZ-2201 LQZ(G)系列球型支座

兹授予河北路泽新材料科技有限公司为我公司公路桥梁LQZ(G)系列球型支座的**生产使用单位**。

授权区域: 贵州省。

授权期限: 2022年4月2日至2023年4月1日。

中标后签订合同,必须持有本次授权证书原件,否则授权无效。

授权方(盖章): 贵州省交通规划勘察设计研究院股份有限公司
 授权日期: 2022年04月02日

生产授权证书

Production Authorization Certificate

发证日期: 2022年03月30日 证书编号: FHCC-CEST-LNR202217

根据交通运输行业标准《公路桥梁高阻尼隔震橡胶支座》和《科技成果授权及监管办法》的相关文件规定,在对你公司生产下述产品的检查中,各项指标均符合交通产品标准和技术质量要求,特颁发此生产授权证书。

公司名称: 河北路泽新材料科技有限公司
 工厂地址: 河北省衡水市高新区北方工业基地迎宾大街10号
 产品名称: LNR系列公路桥梁水平力分散型橡胶支座
 有效日期: 2022.03.30-2023.03.29

授权模式: 生产授权+质量年审

中交第一公路勘察设计研究院有限公司
CCCC FIRST HIGHWAY CONSULTANTS CO.,LTD.

西安中交土木科技有限公司
CCCC CIVIL ENGINEERING SCIENCE & TECHNOLOGY CO.,LTD.

可经<http://app.vcivil.com>查询证书真伪

Authorization



中国交建
CHINA COMMUNICATIONS CONSTRUCTION

项目生产授权证书

Production Authorization Certificate

发证日期：2019年09月12日 证书编号：FHCC-CEST-1928

根据《科技成果授权及监管办法》相关规定，经审查，贵公司日常生产制造流程符合交通产品质量管控标准。特针对以下项目颁发生产授权证书：

公司名称：河北路泽新材料科技有限公司
地址：河北省衡水市高新区北方工业基地迎宾大街10号
项目名称：
授权产品：HDR、LNR、JPZ桥梁支座

授权模式：生产授权+项目质量管控

西安中交土木科技有限公司
CCCC CIVIL ENGINEERING SCIENCE & TECHNOLOGY CO., LTD.
可经<http://www.yCivil.com>查询真伪



CRCC
中国铁建

2022年物资合格供应商

QUALIFIED SUPPLIERS OF MATERIALS IN 2022

河北路泽新材料科技有限公司：

经审查，贵单位通过了中铁十五局集团有限公司2022年物资合格供应商资格审查，作为中铁十五局集团有限公司物资年度合格供应商。
特颁发此证书。

证书有效期：即日起至2023年2月28日
证书编号：CRCC15G2022030804（防水材料）

中铁十五局集团有限公司
物资设备集中采购中心
2022年5月10日



CRCC
中国铁建

2021年物资合格供应商

河北路泽新材料科技有限公司：

经评审，贵单位通过了中铁十五局集团有限公司2021年物资合格供应商招募，作为中铁十五局集团有限公司物资年度合格供应商。
特颁发此证书。

证书有效期：2022年5月31日
证书编号：CRCC15G2021030803（支座）
CRCC15G2021030805（伸缩缝）

中铁十五局集团有限公司
物资设备集中采购中心
2022年5月10日

Model Inspection Report



MA 北京城安建设工程检测有限公司
 150101060007
 数据有效期至 2021.09.07
 BEIJING CHENG'AN CONSTRUCTION PROJECT
 INSPECTION CO.,LTD

检测报告

DETECTING AND ANALYZING REPORT

项目编号: CAIC/ZNQ-2021-012
 SERIES NUMBER
 项目名称: 屈曲约束耗能支撑力学性能测试
 PROJECT NAME
 委托单位: 中安城投建设有限公司
 ENTRUSTING UNIT
 检测类别: 委托检测
 DETECTING TYPE
 检测单位: 北京城安建设工程检测有限公司
 DETECTION UNIT
 报告发送日期: 2021年7月27日
 REPORTING DATE

地址: 北京市北京经济开发区地盛北街1号院31号楼2层205室
 Address: Room 205, F2, Building No.31, No1 Dishengbei Street, Economic and Technological
 Development Zone, Beijing City
 电话: 010-6027 3283 传真: 010-6027 3283
 Tel: 010-6027 3283 Fax: 010-6027 3283
 电子邮件: occupyheart@126.com 邮编: 100176
 E-mail: occupyheart@126.com Postcode: 100176

MA 210021349151
ILAC-MRA **CNAS** 中国认可
 国际互认
 检测
 TESTING
 CNAS L3370

检验报告

报告编号: A11850F202110172

产品名称: 板式橡胶支座

委托单位: 河北路泽新材料科技有限公司

检验类别: 型式检验

国家工程橡胶产品质量检验检测中心(河北)
 恒为检验检测认证(河北)集团有限公司

防伪码: 82V2Z4



报告编号	XJGZ-2022-X01
委托编号	XJGZ-2022-X01

MA
 223101060007

型式检验报告

试件名称: 黏滞阻尼器(VFD)
 试件型号: VFD1000kN×100
 委托单位: 河北路泽新材料科技有限公司
 检验类别: 委托检验

新疆减隔震工程技术研究院(有限公司)

MA 210021349151
ILAC-MRA **CNAS** 中国
 国际
 检测
 TES
 CNA:

检验报告

报告编号: A34915F202204150

产品名称: 板式支座

委托单位: 中交二航院山东LNG项目工程码头工程项目经理部

检验类别: 委托检验

国家工程橡胶产品质量检验检测中心(河北)
 恒为检验检测认证(河北)集团有限公司

防伪码: 2D04JJ



Inspecting Capacity

Rubber material Appearance testing

Slow testing

Mechanical properties

Dynamic testing

Overloading test

Functional Testing



04



Achievement show

专业，让建筑更安全

Professionalism makes buildings more secure

Achievement show

Haikou Meilan International Airport





Achievement show

Shaanxi Olympic Sports Center Gymnasium





Achievement show

Exhibition Center of Northeast Asia International Machinery City





Achievement show



Applications on bridges and roads.



Contact with us

专业，让建筑更安全

Professionalism makes buildings more secure

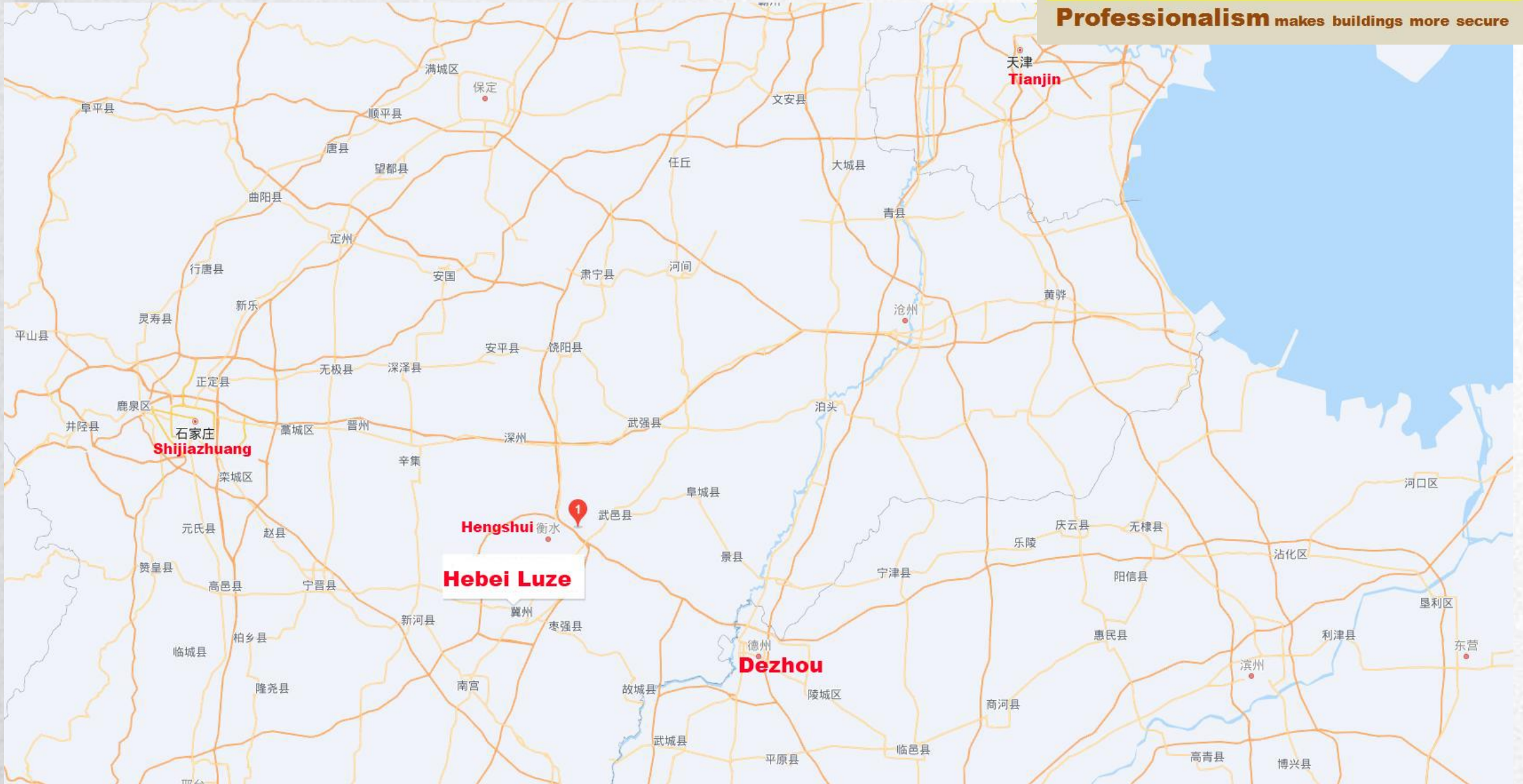



Contact with us



Henley Wang

Mp.86-19930390226(wechat & whatsapp)

Email: henleywang@zohomail.com

Address: Yingbin Road, High-tech Industrial Development Zone,
Jizhou District, Hengshui, Hebei Province-053200. China.





Thanks

Welcome you to visit our factory